

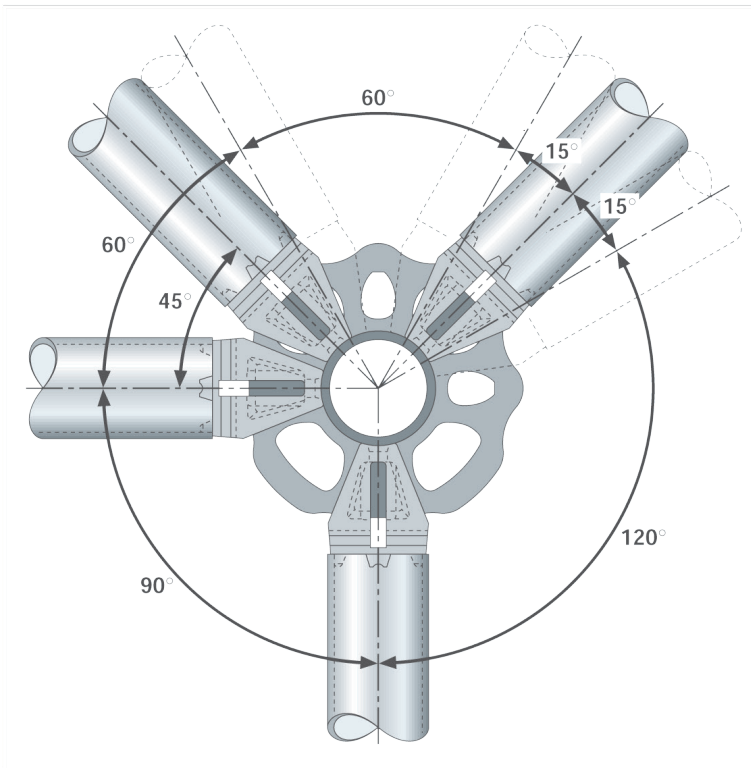

SYSTEM SCAFFOLD

FUTURO RING SYSTEM

User Guide



GENERATION
HIRE & SALE

Altrad Generation Hire & Sale

Support for Construction & Industry

Altrad Generation is the UK's leading supplier of: Scaffolding, Temporary Fencing, Light Access, Edge Protection, Safety Decking and Groundworks for hire and sale.

OUR **CUSTOMER COMMITMENT** IS TO DELIVER:



BEST QUALITY

We work closely with our suppliers to ensure consistent product quality every time. All our products are specified to meet or exceed statutory requirements, verified by our Quality Assurance team.



BEST AVAILABILITY

Our nationwide branch network, transport fleet and stock holding ensure we can supply your equipment needs. What, When and Where you need equipment.



BEST PARTNERSHIP

We can take care of all your equipment needs; supplemented by a full range of engineering, design, specification and business services. Our focus is to work together, supporting the growth of your business.



BEST VALUE

Our global supply chain, purchasing and lean business means we don't pass on unnecessary costs to you. We aim to provide consistently low prices and the best value when you buy or hire from us.

Contents

Altrad Futuro	4-6
General	7-9
Component Listings	10-14
Assembly of Joint Connection	15
Altrad Futuro Facade Scaffold.....	16-22
Assembling Further Scaffold Units	23-34
Assembly Variants & Installation of Additional Components.....	35-39
Dismantling Altrad Futuro Modular System as Facade Scaffold	39
Use of Altrad Futuro Modular System as Facade Scaffold	39
Altrad Futuro as Birdcage Scaffolds	40-53
Altrad Futuro as Round Scaffolding.....	54-56
Capacity of Items.....	57-70
Design Details	71-72
Rescue Plan	73
NASC Code of Practice.....	74

Disclaimer

Whilst Generation (UK) Ltd has taken every reasonable effort to ensure the information contained within this publication is correct and complete at the time of printing, you should be aware that there will be periodical changes and Generation (UK) Ltd does not accept any liability for any inconvenience, loss or damage caused as a result of any inaccuracy or omission within this publication.

Copyright

No unauthorised reproduction of any images, text or other matter contained herein is permitted. All rights are expressly reserved, including copyright, design right, moral and patent rights (where applicable). We reserve the right to take legal action in respect of any infringement of said rights.

Altrad Futuro

New dimensions in the environment of professional and cost-effective scaffolding. The fully approved modular scaffold system ALTRAD Futuro meets all requirements of EN 12810 and EN 12811-1.

The Key to Success

ALTRAD Futuro is the modular scaffolding system for industrial and civil engineering, where adaptable heavy-duty scaffolding systems are especially important.

The key to the success of ALTRAD Futuro in industrial applications is the tension - optimised socket plate, which contains 8 specially formed openings capable of taking up to eight ledgers / diagonals. Both socket plate and connection head are optimised by FEM (finite-element-method).

Because of the way the openings are formed, virtually any angle can be set, as a result, ALTRAD Futuro scaffolding can be erected even in areas where access is restricted.

Scaffolds are built using multi boarded levels reducing the need for ledgers as the steel boards form an integral part of the structure thus saving material, weight and labour, making the system one of the quickest to erect and dismantle in a safe manner.

Industrial Scaffolding

A most flexible assembly even in areas where access is restricted because of pipe work or cables.

Renovation & Restoration Works

An optimised multi purpose adaption to historic buildings, churches and sculptures with their irregularities is possible.

Maintenance and Assembly on Ships and

Aircrafts

Efficient and cost effective when scaffolding around convex shaped ships using suspended or independent scaffolds.

Other Applications

Stair Towers

Birdcage Scaffoldings

Extended Working Platforms

Independent Scaffoldings

Emergency Support

Public Events

Flood-Protection

Quality and Safety

High quality standards characterise the whole modular system. In house inspection, third party supervision and the requirements of DIN EN ISO 9001, latest standard, guarantee best performance.

For long durability all steel items are produced with a hot-dip galvanised finish.

The relevant individual regulations and generally recognised codes of practice must always be observed. In particular:

- The British approval
- EN12810 and EN12811-1
- Industrial safety regulations as well as further regulations

Scaffolding parts should be checked before use.

Altrad Futuro

Eight Holes - But No Handicap

- Up to eight connections per joint
- Option to attach horizontals at right angles with high accuracy at the required level
- Free choice of angles between horizontals using large or small connection gaps
- Load transfer aligned to axes with positive connections
- The flat shape of the connection plate means no mortar, dirt, ice, grit, blasting debris etc. can accumulate
- High joint load capacity and stiffness
- Can be adapted to suit any plan shape and form of construction by using the variable connection options the choice of spans available and freely selectable scaffold height increments of 500mm

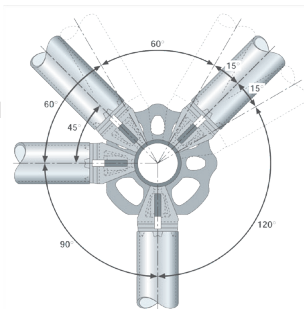

Right Angles – If You Want Them

The use of the small connection gaps for connecting horizontals allows a 90° angle to be created between them – essential for certain users. The larger gaps allow angles between 30° and 60°. These options allow practically any angle to be set and shape form of construction to be scaffolded.

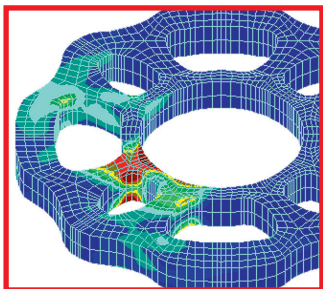

More Mathematics for Less Weight.

The use of finite element methods (FEM) on a three dimensional model allows material shapes and thicknesses to be optimised to meet the required applied loads. This produced the sinusoidal shape and weight savings of 10% as well as clear advantages in erection, safety in use, joint stiffness and storage space requirements.

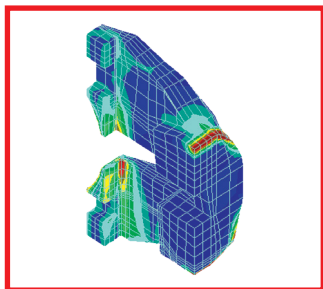

Increase In Bending Moment & Shear Length.

Using FEM analysis, the height of connection heads as well as the shape and thicknesses are optimised to produce higher reserves of safety. This higher load capacity pays off particularly for scaffolds used under demanding conditions.

Altrad Futuro

Functional versatility

ALTRAD Futuro has the right type of decking available for every job. Tough hot-dipped galvanised steel and, full aluminium decks perfect for construction and heavy industry.

Width + Lengths

Bay width (mm): 730, 1090

Bay length (mm): 730, 1040, 1090, 1570, 2070, 2570, 3070

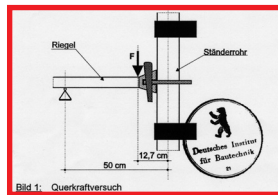
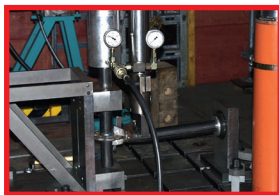
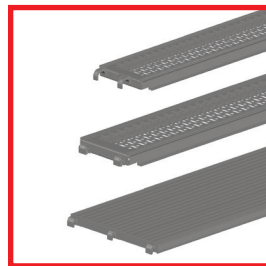

Quality is our best product

In addition to third party inspection of manufacturing by a named test-laboratory, our in-house supervision guarantees a sustainable high standard of quality and with that, the safety of the owners and users, through extensive load capacity tests, using our own testing facilities.

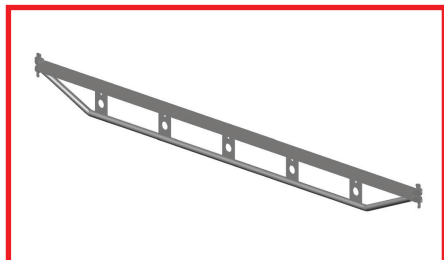

U-Double ledger for use with U-Support

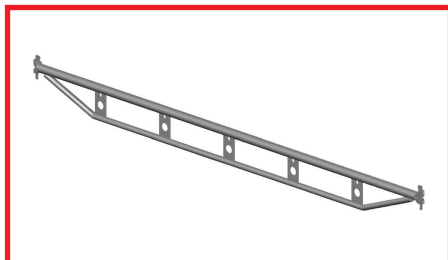

Double ledger for use with Tubular-Support

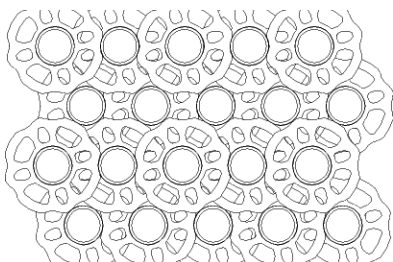

Simpler Storage

As well as the advantages during assembly and its high reserves of safety, the new shape of the socket plates also has storage benefits. The stacked volume of the standards is about 5% smaller and the higher resistance to rolling makes storage more secure.

You can't test quality into a product; it has to be produced. A high automated production with modern welding robots assures a production at the highest level.

General

Preliminary Notes

The ALTRAD Futuro modular system should only be assembled, dismantled and refitted by competent, appropriately trained persons. Reference is made to the requirements of the Health and Safety at Work Act 1974, Construction Regulations Safe Place of Work Act 1996 and the Work at Height Regulations 2005. Within the framework of the user guide we will give the erector and the user the opportunity to take into account the requirements of the Health and Safety at Work Act 1974.

A suitable and sufficient risk assessment of the assembly situation is necessary prior to erection based on the prerequisites of the above regulations. The special features of each individual case are to be taken into consideration during this process.

A basic prerequisite is that the following instructions are taken into consideration. Reference is made to the fact that all instructions, in particular those relating to stability, is only applicable when using original ALTRAD Futuro components identified in accordance with approval Z-8.22-841. The assembly of external brands may lead to safety defects and inadequate stability.

A plan is to be drafted by the contractors of the scaffold construction work for assembly depending on the complexity, for assembly, conversion and dismantling (assembly instructions) or drafted by a qualified person appointed by him. These assembly and use instructions may be used for this purpose, supplemented by detailed information for the respective scaffolding.

Comments are made throughout the User Guide to provide the user with key information.

		
Information	Important note or warning	Risk of falling



Assembly of the Altrad Futuro Modular System Only:

- Under the supervision of a qualified person
- By trained employees
- On the basis of the risk assessment
- In consideration of this user guide
- With components marked in accordance with approval Z-8.22-841

General

Scaffold System

The ALTRAD Futuro modular system is made out of hot dip galvanised steel standards and transoms. The standard tubes are spaced at a distance of 500mm with welded perforated disks whilst the transoms have connecting heads at their ends with a wedge. The span lengths and widths are 0.73m, 1.09m, 1.57m, 2.07m, 2.57m and 3.07m. The vertical distance of the deck plane is 2.00m whereby the requirements of height class H1 in accordance with DIN EN 12811-1 are fulfilled. The junction of the standards takes place by tube connectors arranged at the head.

The stiffening of the scaffolds takes place by vertical and horizontal diagonals.

The manufacture and marking of the components is governed in the general technical approval Z-8.22-841.



The ALTRAD Futuro modular system is to be checked before commissioning. Testing is to be documented.

Watch Us Put Altrad Futuro To The Test

To demonstrate Altrad Futuro's key strengths we have decided to put Futuro to the test in the form of a timelapse video. The video gives you a glimpse at just how quick Altrad Futuro is in all aspects of scaffolding from the logic behind basing out to the speed of erection and the ease of dismantle compared to Lok type system scaffold and the traditional Tube and Fitting whilst also highlighting the benefits of Altrad Futuro compared to other ring scaffolds on the market.



To view the video please visit our YouTube page www.youtube.com/user/GenerationUKLtd

General

Site Safety

- It is the responsibility of the user to check the ALTRAD Futuro modular system before use for any apparent defects. They are responsible for use in conformity with conditions and maintenance of operational safety of the scaffold. Scaffolds are required to be inspected every seven days by the user and records kept.
- Before erection of a scaffold all ground must be inspected. The ground should be level and supported using sole boards.
- Defects which occur during use as a result of severe weather or construction work etc. are to be notified immediately to the scaffold contractor.
- Safe access and egress to and from the scaffold must be ensured using the most appropriate method. Ladders used should be properly secured, positioned at an angle of 4 to 1. Ladders should extend no less than 1m above the working platform. A ladder access trap door or handrail safety gate should always be employed.
- The user of the scaffold should prevent access by unauthorised persons.
- Trapdoors of access decks are to be kept closed during work on the scaffold.
- Work at several levels is to be avoided. There is an increased risk of accident as a result of falling objects.
- Scaffolds must be tied and adequately braced in line with the recommendations in this guide.
- All working platforms require double handrails and toe boards. Additional protection such as debris netting, brick guards, sheeting and protection fans may be required.
- The ALTRAD Futuro modular system, in the standard design, may be loaded as a façade scaffold in accordance with the approval with a maximum useful load of $p = 2.0 \text{ kN/m}^2$ on one platform layer. Larger surface loads are possible, however must be individually verified. The scaffold or parts thereof could collapse in the event of overloading.
- When using as trap or roof scaffolds no materials should be stored on the platform or equipment deposited. The risk of injury of falling persons is increased.
- Never add sheeting, hoarding or netting unless the structure has been specifically designed for that purpose.
- The user of the scaffold may not dismantle side protection parts or scaffold couplers or change anything on the basic structure. Care should be taken to ensure that this does not take place by other persons involved in the construction. Any missing scaffold couplers or inadequate foundation for the scaffold standards may lead to collapse of the whole scaffold. If changes are made during the course of construction, then these are to be performed by the qualified scaffold erectors.
- The ALTRAD Futuro modular system may only be changed by the qualified scaffold erectors.



Modifications to the ALTRAD Futuro modular system should only be carried out by the scaffold construction contractor.

Component Listing

6 Ton Adjustable Base Jacks

Used at the base of the scaffolding for the levelling of the kicker lift in conjunction with the starting collar.

Code	Description	Weight
207005	6 Ton Base Jack	4.70kg
207200	6 Ton Swivel Base Jack	4.30kg



230mm Starting Collar

Used for the ease of basing out a scaffolding once placed onto the jack, this item can also be used in conjunction with twin headed hop up brackets for standard location points amongst other uses.

Code	Description	Weight
591007	230mm Starting Collar	1.60kg



Vertical Standard with fixed spigot

48.3mm x 3.2mm galvanised steel tube with 8 hole connecting discs at 0.5m centres along the total length. The small openings on the connecting disc are predominantly used for ledgers & transom locations with the larger openings being used for splayed scaffolding and vertical braces. Standards with the option of a bolted spigot are also available upon request.

Code	Description	Weight
591000	0.5m Standard (1 x Disc)	3.20kg
591001	1m Standard (2 x Disc)	5.40kg
591002	1.5m Standard (3 x Disc)	7.70kg
591003	2m Standard (4 x Disc)	9.90kg
591005	3m Standard (6 x Disc)	14.40kg
591006	4m Standard (8 x Disc)	18.80kg



Vertical Open-Ended Standard

48.3mm x 3.2mm galvanised steel tube with 8 hole connecting discs at 0.5m centres along the total length. The small openings on the connecting disc are predominantly used for ledgers & transom locations with the larger openings being used for splayed scaffolding and vertical braces.

Code	Description	Weight
591022	1m Open Ended Standard (2 x Disc)	4.50kg
591023	1.5m Open Ended Standard (3 x Disc)	6.70kg

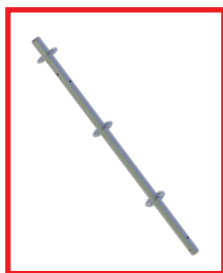

Component Listing

O Ledger / Transom

48.3mm x 3.2mm galvanised steel tube manufactured in a series of lengths from 0.15m - 3.07m, this component is used as a ledger / transom & guardrail. Lengths up to 1.40m are used as deck supporting transoms due to the tubular nature of the Futuro 'O' system.

Code	Description	Weight
595148	0.15m Ledger / Double Wedge Head	1.10kg
591439	0.39m Ledger	1.80kg
591030	0.42m Ledger / Transom	2.00kg
591031	0.73m Ledger / Transom	3.00kg
591033	1.09m Ledger / Transom	4.10kg
591035	1.40m Ledger / Transom	5.40kg
591037	1.57m Ledger	5.60kg
591038	2.07m Ledger	7.20kg
591039	2.57m Ledger	8.80kg
591040	3.07m Ledger	10.30kg

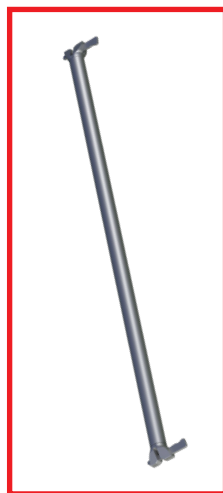

Double Ledger / Transom (DBL) 210mm Height

This component is used when greater loadings are required or when system decks are to be supported over longer spans. Ideally used when erecting crash decks or creating cantilevered scaffolds.

Code	Description	Weight
591050	1.40m Double Ledger	8.90kg
591043	1.57m Double Ledger	9.90kg
591045	2.07m Double Ledger	13.10kg
591046	2.57m Double Ledger	16.20kg
591047	3.07m Double Ledger	19.40kg

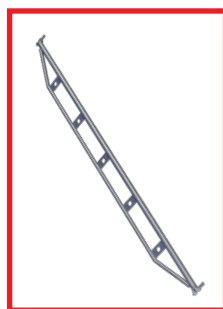

NEW Double Ledger / Transom (DBL) 105mm Height

With a reduced height giving greater head clearance this component is used when greater loadings are required or when system decks are to be supported over longer spans. Ideally used when erecting crash decks or creating cantilevered scaffolds.

Code	Description	Weight
595195	1.40m Double Ledger	9.20kg
595196	2.07m Double Ledger	13.70kg
595197	2.57m Double Ledger	17.20kg



Component Listing

Ledger to Ledger Intermediate Transom

The intermediate transom enables the splitting of a bay in order to create an opening between decked platforms, this component locates over the ledgers between each set of standards. This item is also used for the supporting of Timber scaffolding boards when system decks are not used.

Code	Description	Weight
591049	1.09m Intermediate Transom	5.10kg
591415	1.40m Intermediate Transom	6.20kg
591051	1.57m Intermediate Transom	6.80kg
591559	2.07m Intermediate Transom	10.30kg
591416	2.57m Intermediate Transom	12.50kg
591560	3.07m Intermediate Transom	15.00kg

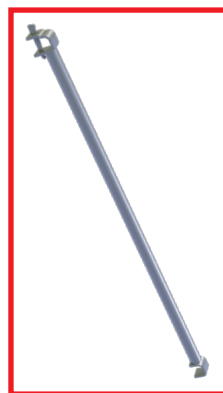

Ledger to Deck Intermediate Transom

The ledger to deck transom allows for the creation of an opening to the side of a decked platform with one side connecting over the scaffolding ledger and the other side being connected to a steel deck. This item is often used when creating an opening for traditional ladder points through decked platforms.

Code	Description	Weight
591531	1 Deck Support Ledger to Deck Transom	2.70kg
591532	2 Deck Support Ledger to Deck Transom	3.80kg
591533	3 Deck Support Ledger to Deck Transom	5.00kg

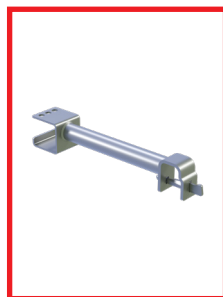

Deck to Deck Intermediate Transom

The deck to deck transom allows for the creation of an opening in the middle of a decked platform with both ends of the transom being connected to a steel deck. Ideally used for creating openings in decked platforms for pipe work and construction support beams.

Code	Description	Weight
591535	1 Deck Support Deck to Deck Transom	2.30kg
591536	2 Deck Support Deck to Deck Transom	3.40kg
591537	3 Deck Support Deck to Deck Transom	4.50kg

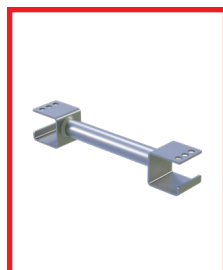

Component Listing

Vertical Brace

48.3mm x 2.7mm galvanised steel tube with a swivel wedge fitting to either end, sometimes referred to as a face brace. Available to fit all bay lengths with up to 4 different height sizes. Designed to reinforce a scaffolding structure vertically, this item can also be used for supporting scaffolding fans and the erection of cantilevered scaffolds.

Code	Description	Weight
591090	0.5m H x 2.07m L Vertical Brace	7.80kg
591089	1.0m H x 1.09m L Vertical Brace	6.00kg
591550	1.0m H x 1.40m L Vertical Brace	6.80kg
591084	1.0m H x 1.57m L Vertical Brace	7.10kg
591085	1.0m H x 2.07m L Vertical Brace	8.40kg
591086	1.0m H x 2.57m L Vertical Brace	9.80kg
591087	1.0m H x 3.07m L Vertical Brace	11.20kg
591078	1.5m H x 1.57m L Vertical Brace	8.10kg
591079	1.5m H x 2.07m L Vertical Brace	9.20kg
591080	1.5m H x 2.57m L Vertical Brace	10.50kg
591081	1.5m H x 3.07m L Vertical Brace	11.80kg
591071	2.0m H x 0.73m L Vertical Brace	8.20kg
591072	2.0m H x 1.09m L Vertical Brace	8.50kg
591073	2.0m H x 1.40m L Vertical Brace	9.00kg
591074	2.0m H x 1.57m L Vertical Brace	9.30kg
591075	2.0m H x 2.07m L Vertical Brace	10.30kg
591076	2.0m H x 2.57m L Vertical Brace	11.40kg
591077	2.0m H x 3.07m L Vertical Brace	12.60kg

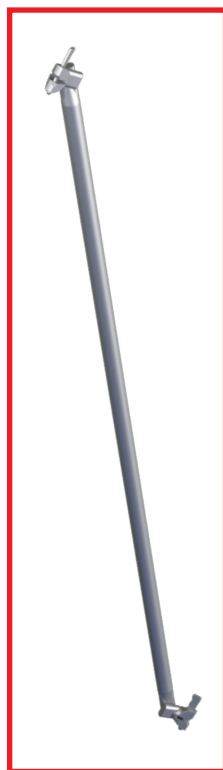

Horizontal Brace (Non-Square Bay with Angled Wedge Head)

48.3mm x 3.2mm galvanised steel tube with fixed angled wedge heads to either end, used to create rigidity in the horizontal plane when decks are not required. Also used for the basing out as this item aligns the scaffolding structure at right angles so that the bays are square, often referred to within the UK as a plan brace.

Code	Description	Weight
591096	2.57m x 1.09m Horizontal Brace	9.60kg
591100	3.07m x 1.09m Horizontal Brace	11.10kg
591540	3.07m x 1.40m Horizontal Brace	11.40kg



Component Listing

Plan Brace (Square Bay with Standard in-Line Wedge Head)

48.3mm x 3.2mm galvanised steel tube with fixed wedge heads to either end, used to create rigidity in the horizontal plane when decks are not required. Also used for the basing out as this item aligns the scaffolding structure at right angles so that the bays are square.

Code	Description	Weight
591106	2.57m x 2.57m Plan Brace	12.20kg



320mm O System Ledger Deck (standard deck)

A high load bearing steel perforated deck, fully galvanised with drop forged connecting claws to fit 48.3mm diameter scaffolding tube. Integrated anti-lift & anti-tilt devices with a minimum 5KN/m² working load capacity.

Code	Description	Weight
591107	0.73m x 320mm Steel Deck (class 6)	7.20kg
591108	1.09m x 320mm Steel Deck (class 6)	9.30kg
591109	1.40m x 320mm Steel Deck (class 6)	11.20kg
591110	1.57m x 320mm Steel Deck (class 6)	12.30kg
591111	2.07m x 320mm Steel Deck (class 6)	15.30kg
591112	2.57m x 320mm Steel Deck (class 5)	18.30kg
591113	3.07m x 320mm Steel Deck (class 4)	21.30kg

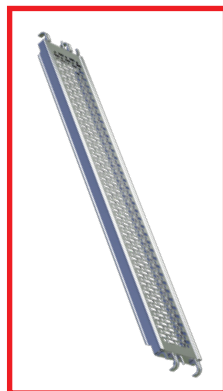

190mm O System Ledger Deck (Skinny Deck)

A high load bearing steel perforated deck, fully galvanised with drop forged connecting claws to fit 48.3mm diameter scaffolding tube. Integrated anti-lift & anti-tilt devices with a minimum 5KN/m² working load capacity.

Code	Description	Weight
591114	1.09m x 190mm Steel Deck (class 6)	7.30kg
591139	1.40m x 190mm Steel Deck (class 6)	8.70kg
591115	1.57m x 190mm Steel Deck (class 6)	9.50kg
591116	2.07m x 190mm Steel Deck (class 6)	11.70kg
591117	2.57m x 190mm Steel Deck (class 5)	14.10kg
591118	3.07m x 190mm Steel Deck (class 4)	16.40kg

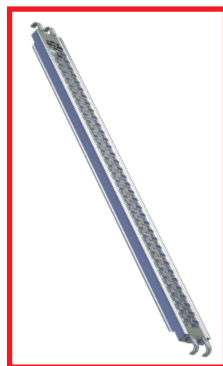

Component Listing

Alloy Ladder Deck

Full aluminium frame & deck with drop forged connecting claws to fit 48.3mm diameter scaffolding tube, complete with fully integrated drop-down ladder, 640mm wide platform will replace 2 x 320mm Steel decks.

Code	Description	Weight
591119	2.57m x 640mm Alloy Ladder Deck	29.60kg
591120	3.07m x 640mm Alloy Ladder Deck	33.30kg

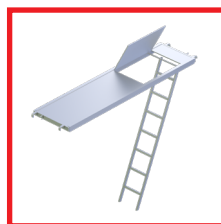

Corner Infill Deck

A galvanised steel deck that works in conjunction with the hop-up bracket at a 90° internal or external corner.

Code	Description	Weight
591351	1 Board Corner Infill Deck	5.70kg
591352	2 Board Corner Infill Deck	12.30kg



O System 4 Wedge Head Steel Lattice Beam

Used for bridging clear spans of up to 6.14m between two sets of standards. Commonly used on system loading bays or when cantilevering out from buildings.

Code	Description	Weight
591571	2.57m x 0.5m Steel Lattice Beam 4 HD	29.70kg
595150	3.07m x 0.5m Steel Lattice Beam 4 HD	37.10kg
595135	4.14m x 0.5m Steel Lattice Beam 4 HD	49.20kg
595153	6.14m x 0.5m Steel Lattice Beam 4 HD	69.10kg

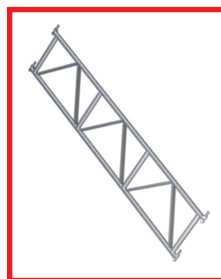

0.39m & 0.73m Hop Up Bracket with spigot

Used to extend the depth of a scaffold by 1 x 320mm deck / 2 x 320mm deck. If required the spigot will then allow for the fitting of a 1m standard with 2 x 0.39m / 0.73m guardrails.

Code	Description	Weight
591179	0.39m Hop Up Bracket with Spigot	3.90kg
591420	0.73m Hop Up Bracket with Spigot	5.90kg

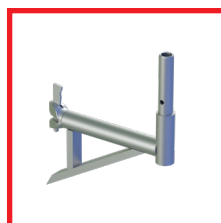

Hop Up Extension Bracket (190mm)

Used in conjunction with the 0.39m / 0.73m hop up bracket with spigot. The bracket slots down over the hop up bracket spigot allowing for a 190mm deck extension to be added.

Code	Description	Weight
591177	190mm Hop Up Extension Bracket	0.85kg

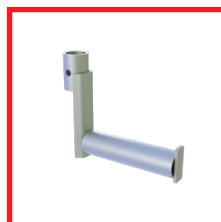

Component Listing

Variable Hop Up Bracket (1&2 Deck)

Used to extend the depth of a scaffold the variable hop-up bracket can be used as a 1 x 320mm deck or a 2 x 320mm deck support. By removing the wedge head and re-inserting in the opposite direction the bracket can very easily be adapted to do the job of two separate components.

Code	Description	Weight
591182	Variable Hop Up Bracket 1 & 2 Deck	5.60kg

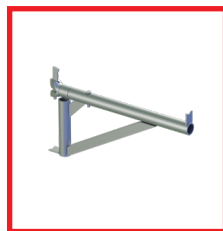

0.73m Double Wedge Head Hop Up Bracket

Used to extend the depth of a scaffold by 2 x 320mm decks, due to having a double wedge head this item can also be used as a ledger / transom or an alloy stair flight support.

Code	Description	Weight
591181	0.73m Hop Up Bracket 2 HD	4.90kg

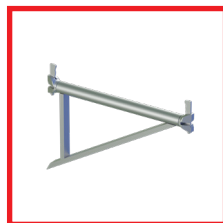

1.09m Cantilever Bracket

Used to extend the depth or length of a scaffold by 3 x 320mm decks, with 3 wedge heads this bracket is attached to the standards at two points with the third wedge head allowing for starting collars or vertical standards to be attached.

Code	Description	Weight
591180	1.09m Cantilever Bracket with 3 HD	9.70kg

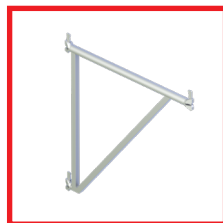

Timber Toe Board

150mm high timber toe board with galvanised steel fixing plates to either end.

Code	Description	Weight
591150	0.73m x 150mm Timber Toe Board	1.60kg
591151	1.09m x 150mm Timber Toe Board	2.30kg
591152	1.40m x 150mm Timber Toe Board	2.80kg
591153	1.57m x 150mm Timber Toe Board	3.10kg
591154	2.07m x 150mm Timber Toe Board	4.10kg
591155	2.57m x 150mm Timber Toe Board	5.00kg
591156	3.07m x 150mm Timber Toe Board	5.90kg

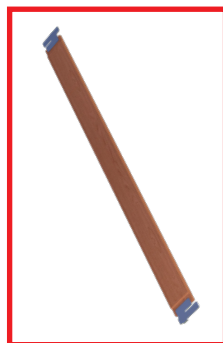

Component Listing

Guardrail Post Off-Set

Used to create access points mid bay, a second ledger must be installed below the decked lift so that the post can be attached at two points. This will enable the fitting of double guardrails and a ladder safety gate.

Code	Description	Weight
591167	Guardrail Post / Ladder Gate Post Off-set	8.10kg

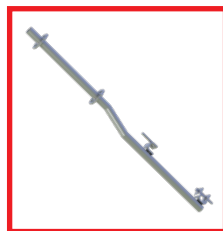

Suspended Scaffold Connector

The suspended scaffold connector is designed for bridging the connection of two standards, always used in pairs this component is ideally used when a scaffolding structure is to be suspended or craned into position. This fitting creates a positive connection to the discs either side of the joint in order to combat the tension that will be placed upon it.

Code	Description	Weight
591029	Scaffold Connector 500mm	3.00kg

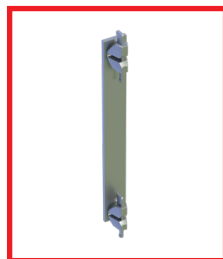

Steel Gap Cover Plate

A perforated 320mm x 12.5mm steel plate for bridging gaps between decks of up to 140mm, this plate is held in place with the aid of over-sized plastic screw plugs.

Code	Description	Weight
595157	0.73m x 320mm Gap Cover Plate	2.40kg
595158	1.09m x 320mm Gap Cover Plate	3.40kg
595159	1.57m x 320mm Gap Cover Plate	5.40kg
595160	2.07m x 320mm Gap Cover Plate	7.40kg
595161	2.57m x 320mm Gap Cover Plate	9.40kg
595162	3.07m x 320mm Gap Cover Plate	11.40kg

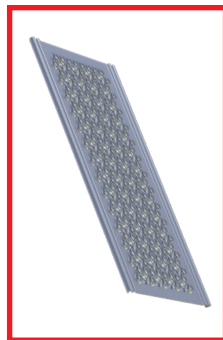

Steel Gap Cover Deck

A perforated 320mm x 25mm steel deck for bridging gaps between decks, this plate is held in place with the aid of over-sized plastic screw plugs.

Code	Description	Weight
595166	1.09m x 320mm Gap Cover Deck	6.44kg

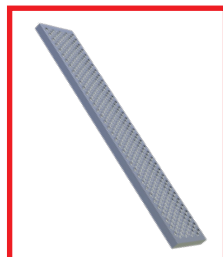

Component Listing

0.15m Ledger / Double Wedge Head Fitting

Used for connecting standards together for double legged scaffolding or off setting standards in order to avoid obstructions when erecting, giving a centre to centre of standard measurement of 154mm.

Code	Description	Weight
595148	0.15m Ledger / Double Wedge Head	1.10kg



Clampable Disc Coupler Fitting (22mm)

This fitting allows for the connection of up to six ledgers or braces at any point along a Futuro standard.

Code	Description	Weight
591440	Clampable Disc Coupler Fitting	1.10kg

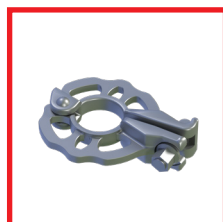

Support Spigot with Fitting (22mm)

A 300mm spigot with half coupler fitting, generally used when attached to a lattice beam or ledger to allow for the connection of a standard at any chosen point.

Code	Description	Weight
591220	300mm Support Spigot with Fitting	1.60kg



Support Spigot with Wedge

A 300mm spigot with a wedge connection, this spigot is used to fix a standard to a steel lattice beam at pre-determined positions that are located along the top cord of the beam. Due to the wedge fitting locating through the top cord of the beam the standards are un-able to swivel at the joint.

Code	Description	Weight
591222	300mm Support Spigot with Wedge	2.10kg

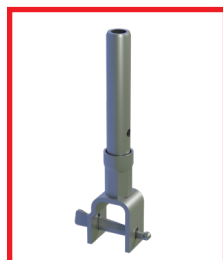

Component Listing

Threaded Spindle with Fitting (22mm)

A 500mm adjustable spindle that enables the levelling of standards when working from un-even starting points.

Code	Description	Weight
591318	500mm Threaded Spindle with Fitting	2.90kg

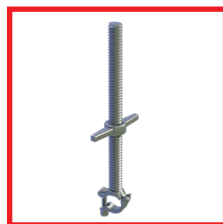

Toe Board Bracket

This fitting is attached to the standards and hooked over the toe board to enable a more permanent and secure fixing connection.

Code	Description	Weight
591430	Toe Board Bracket Fitting	1.20kg



Wedge with Swivel Fitting (22mm)

Used for attaching traditional scaffold tube to the disc of the standard, allows the conversion of scaffolding tube into vertical braces or the tying-in of standards to ledgers on fly past returns.

Code	Description	Weight
591301	Wedge with Swivel Fitting	1.20kg

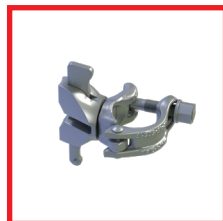

Distance Coupler Fitting (22mm)

Used for attaching two standards together with a distance of 85mm. This fitting allows the indents of the discs on the standard to sit tight up against the other standard with the discs being positioned at different heights.

Code	Description	Weight
591291	Distance Coupler Fitting	1.40kg



Component Listing

Aluminium Staircase Unit

Complete with upper and lower landings, drop forged connecting claws to fit 48.3mm diameter scaffolding tube. This 640mm wide staircase has a loading capacity of 2kn/m².

Code	Description	Weight
591255	1m x 640mm Alloy Staircase	13.70kg
591256	2.57m x 640mm Alloy Staircase	30.00kg
591258	3.07m x 640mm Alloy Staircase	35.00kg



Stair Head Guardrail (Double)

This guard rail frame is attached to the inside stringer of the top flight of stairs to create a safe fixed exit route.

Code	Description	Weight
591281	Stair Head Guardrail Frame	14.70kg

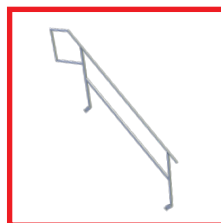

Stair Outer Guardrail (Single Rail Option)

Two guardrails are required per staircase unit, these are fixed top and bottom to the discs of the outside standards.

Code	Description	Weight
591269	3.07m x 2m Single Outer Guardrail	13.40kg

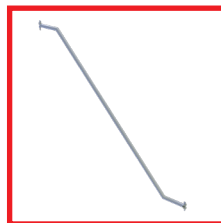

Stair Outer Guardrail Frame (Double Rail Option)

One guardrail frame is required per staircase unit, this is attached over the landing handrails top and bottom.

Code	Description	Weight
591270	2.57m x 2m Double Outer Guardrail	22.80kg
591271	3.07mtr x 2mtr Double Outer Guardrail	25.10kg

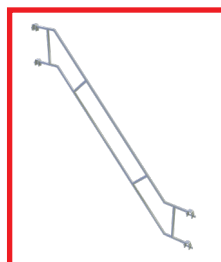

Component Listing

Stair Inner Guardrail (Double)

This guard rail frame is attached to the inside stringer of each staircase unit.

Code	Description	Weight
591283	Inner Guardrail 2.57m & 3.07m x 2m	14.80kg

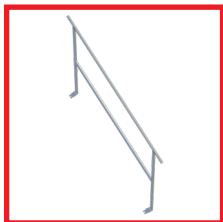

Stair Well Guardrail Frame

This guardrail frame can be attached to the underside of a alloy staircase unit to close off the void below.

Code	Description	Weight
595184	Stair well Guardrail Frame	4.60kg

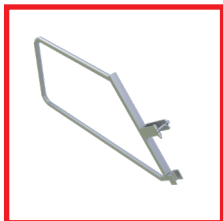

Staircase Guardrail Adaptor

Used in pairs and attached to the outer standard of the stair tower to enable the fitting of the stair outer guardrail frame.

Code	Description	Weight
591568	Staircase Guardrail Adaptor	0.95kg

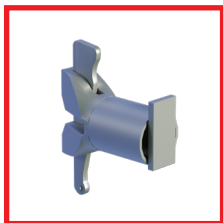

Assembly of Joint Connection

The wedge lock principle was selected as a joint connection (transom – standard tube). This relates to the positive locking of the scaffold with a loosely inserted wedge. A definite frictional connection is achieved with a hammer.

The head is pressed on the upper and lower contact surface against the standard tube (figure 1) which produces an extremely deflection-resistant connection. The transom head piece is pushed sideways over the perforated disk.

The wedge lies horizontal on the transom tube (figure 2) held by a rivet on the top.

By lifting the wedge and inserting, the transom is locked in position by hitting with a 500g hammer until the rebound blow is non positively connected with the standard (figure 3).

The perforated disk (figure 4) has four small holes which are placed at 90°. The transoms are connected if a precise right angle is achieved in the horizontal plan. This automatically sets itself when wedged.

There are slits between the small holes which facilitate a variable transom connection of + 15°. As a result horizontal plans can be formed which do not lie in the 90° screen.

The recesses on the outer edge of the perforated disk not only represent the special appearance of the Futuro scaffold joint but also save weight and ensure a better stackability of the standards in the pallet. Due to the shape they cannot roll away on an uneven surface.

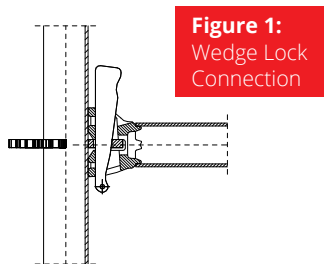

Figure 1:
Wedge Lock
Connection

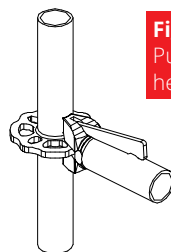

Figure 2:
Pushing in the
head piece.

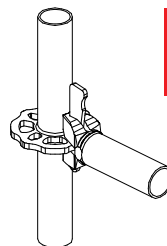

Figure 3:
Wedging the
head piece.

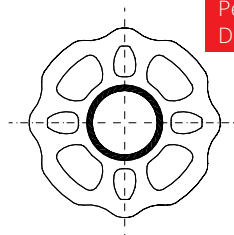

Figure 4:
Perforated
Disk.



Wedges are to be hit immediately after assembly of the components, with a 500g hammer until the rebound blow.

ALTRAD Futuro Façade Scaffold

Standard Design

The assembly and dismantling of the standard design as façade scaffold in accordance with approval Z-8.22-841 is described in chapter 2. The ALTRAD Futuro modular system may be used in the standard design for work scaffold of load class 3, and as trap or roof scaffold.

The scaffold decks used in the trap and roof scaffold may be taken from table 1 (page 19).

If the scaffold with a bay width of 1.09m is used without any side brackets the maximum deck length is 3.07m. Wall ties are to be fixed to every standard every 4m in height. In this case the maximum standing height is 24.5m as to EN 12811.

If the scaffold with a bay width of 1.09m is used with side brackets 0.43m. The side brackets loaded with LC 1 (75kg/m²) the maximum deck length is 2.57m. Wall ties are to be fixed every standard every 4m in height. In this case the maximum standing height is 24.5m as to EN 12811.

If the ALTRAD Futuro modular system is used for scaffolds which deviate from the standard design as façade scaffold, these must be evaluated on the basis of the planning and building law, in accordance with technical building specifications and the stipulations of relevant guidance notes and where necessary, calculated.

These assembly and use instructions only apply in conjunction with the use of original Plettac Assco components which are identified in accordance with approval Z-8.22-841. All scaffold components are to be checked before assembly and use by a visual inspection for any defects.

The assembly of the ALTRAD Futuro modular system as façade scaffold is to be carried out in the sequence of order of the following sections.



For the ALTRAD Futuro modular system as façade scaffold the following applies:

- Regulation in approval Z-8.22-841
- Load class 3
- Useful loads: Cl 3 = 2.0 kN/m²
- Max. standing height = 24m as standard design
- In the event of deviations from the standard design additional proof is required.

Assembly of the First Scaffold Bay

Basic Scaffold

The basic scaffold consists of adjustable bases, starting collars and horizontal transoms parallel and transverse to the façade (figure 5).

First of all, the starting collars are placed on the adjustable bases and connected with the horizontal transoms in accordance with figure 5. The wedges are inserted loose and the transoms are aligned with the aid of a horizontal spirit level. Non-positive wedging should then take place. The precise scaffold layout is given. Due to the low weight

the basic scaffold can be easily moved and placed into the correct position to the façade. The distance should be selected in such a way that the internal edge of the deck to be subsequently connected should not be further than a distance of 225mm from the façade.

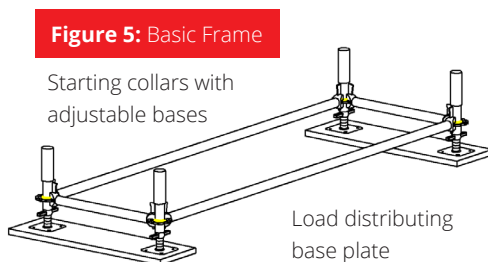

Loading Distributing Base Plate

The ALTRAD Futuro modular system may only be fitted on an adequately firm foundation. If the foundation is not suitably firm, load distribution base plates are to be provided e.g. a scaffold board as shown in figure 5. Where necessary, single part plates can be arranged under each post (figure 6).

With suitable foundation, the substructures are to be secured against sliding. If possible, the base should be balanced out accordingly, so that a horizontal support surface is available.

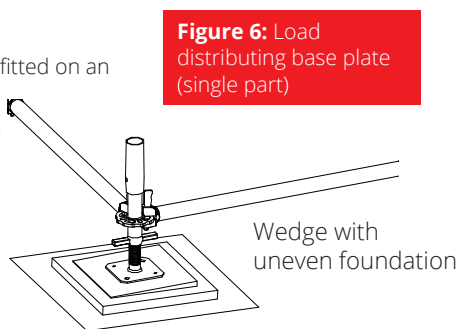

Assembly of the First Scaffold Bay

Adjustable Bases

A 6T Adjustable Base is to be fitted under each modular standard (figure 5). Adjustable bases may be extended, as a rule, up to 250mm.

The possible threaded system extension lengths W (UK base plate up to adjustable nut) are as follows with the scaffold thread.

Total Length L1 (mm)	Jack Extraction Length W (mm)
400	255
600	455
800	605

The thread of the bases is limited at the corresponding points so that further turning is not possible.

Vertical Standards

The vertical posts are placed in the starting collars. Façade side 4.0m long and outside 3.0m long posts are to be fitted (see figure 16, page 27). 500mm above the basic transom a further transom is required transverse to the façade (see structure variants). 730mm or 1.09m system lengths are to be used as transverse transoms.

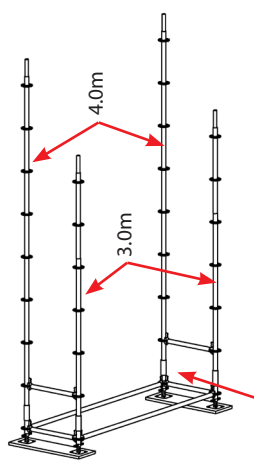

Figure 7: Assembly of the vertical standards

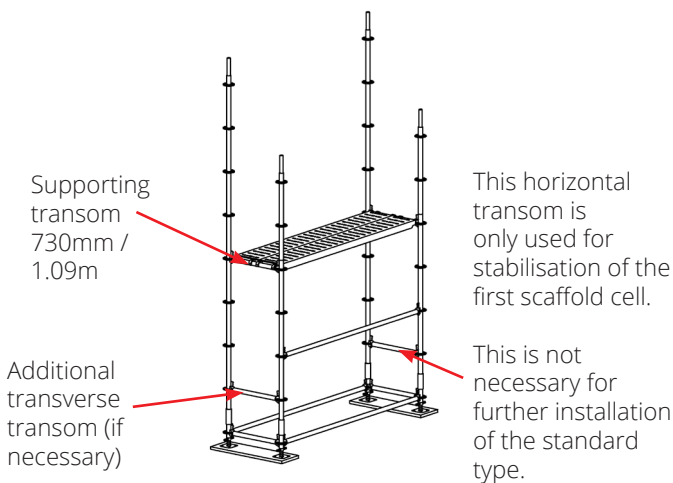

Figure 8: Assembly of the deck

Assembly of the First Scaffold Bay

Assembly of the Decks

Only decks in accordance with table 1 below may be used

Decks for U Support

The support transoms with 730mm system length are to be used for the decks for U support. The claws on the heads of the deck are placed on the sides of the U profile. The floors thus form a horizontal rigid panel and stabilise the scaffold. Depending on the span, two 320mm wide steel panels or one 610mm wide frame plate and/or one 640mm wide step-through are necessary. In order to secure the decks, the deck is to be fitted over the transverse joint.

Decks for Tube Support

In order to support the tube support decks horizontal transoms are to be used with 730mm system length. The panels are placed with claws over the transoms and pushed in the correct position. The lifting retainers automatically lock (check). Depending on the span, two 320mm wide steel panels or one 640mm wide step-through are to be fitted.

Table 1: Standard design deck elements

Description	Use In Trap & Roof Scaffold	Span Length (m)	Load Class (max)
Deck panel steel 32 U support Tube support	Permissible	< 2.07 2.57 3.07	6 5 4
Deck panel steel 19 U support Tube support	Permissible	< 3.07	4
Frame plate aluminium with step-through frame U support	Permissible	2.57 3.07	3
Aluminium step through frame with aluminium deck U support tube support	Permissible	2.57 3.07	4 3



All scaffold levels must be laid out in full. Levels with only a 320mm wide deck cannot stiffen the scaffold.



With decks for tube support it should be checked after assembly, whether the lifting retainers are locked. Where necessary, these are to be manually locked. It should be ensured that the retainer lever can always be moved in the mounting.

Assembly of Further Scaffold Bays

Standard Range

Assembly of further scaffold bays takes place as described in the previous section. The longitudinal transoms at the base are to be arranged continuously (figure 9). A step-through panel is to be fitted in the ascent bay span in place of the steel panels.

Steel panels are to be placed on the bottom transverse transoms for correct support for the ladders.

These horizontal transoms can be removed after assembling the side protection in the deck level + 2m.

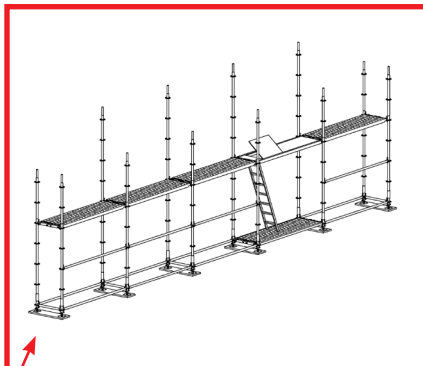

Figure 9: The first scaffold level

Uneven Ground

In the event of inclined ground and when reaching certain layer heights, correspondingly longer vertical posts are to be fitted. These are to be stiffened longitudinally and transverse with transoms and where necessary with diagonals.

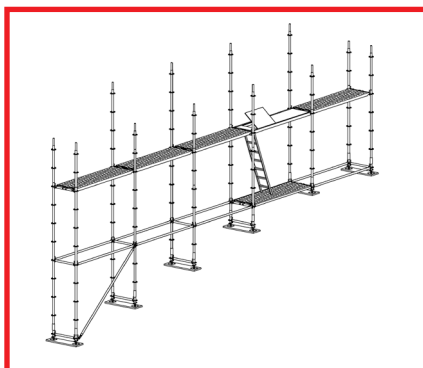

Figure 10: Height compensation in the event of uneven ground.

Assembly of Further Scaffold Bays

Corner Formation

The possible corner formations with the ALTRAD Futuro modular system are multitude. One has to decide between internal and external corners. It is important in this process that with the selected design façade side, brackets can be used and fitted on the scaffold external face of the three part side protection.

Figure 11 shows the possibilities of an internal corner, variant A without brackets and variant B with brackets before the façade. Variant A can be used on an external corner. All variants can be fitted with tube support and with U support (the tube support is shown here).

Figure 11: Equipping internal corners.

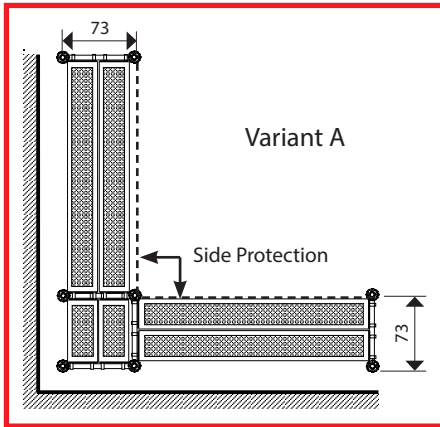

Select the design so that the three part side protection can be properly fitted on the scaffold outside.



The variants which are shown can be fitted with tube support and with U support.

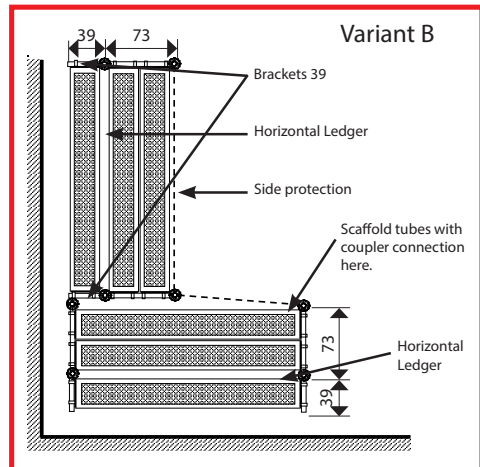

Assembly of Further Scaffold Bays

Figure 12 shows the various possible arrangements for an external corner. Variant C (without brackets) and D (with brackets before the façade) are variable with regard to the position of the scaffolds. Variant E reveals the optimum with the lowest number of posts. A horizontal transom (tube support) and a U double transom are necessary here as support.

Figure 12: Equipping external corners

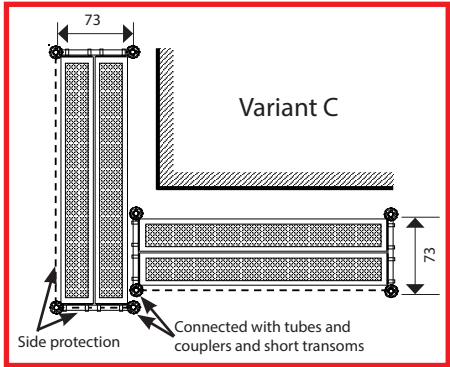

Choose a design so that the three part side protection can be properly fitted on the scaffold outer face.

All variants which are shown can be fitted with tube support and U suport

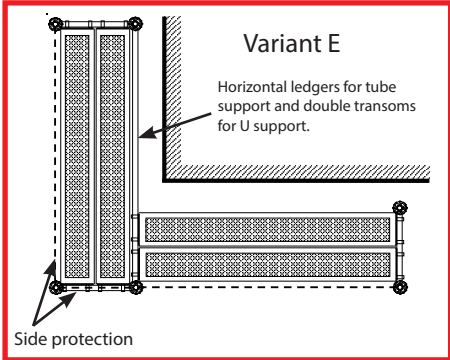
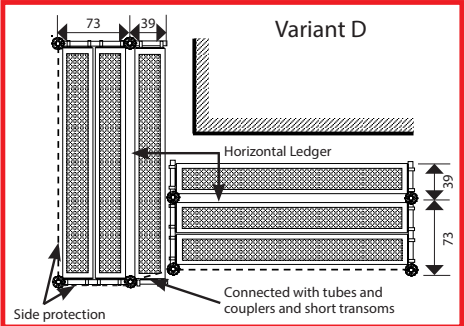

Assembling Further Scaffold Lifts

General

When assembling, refitting and dismantling further lifts of the ALTRAD Futuro modular system, there is a risk of falling. The scaffold construction work must be carried out in such a way that the risk of falling is avoided where possible or the risk is as low as possible. The contractor (scaffold erector) must define suitable measures for avoiding risk or minimising hazards on the basis of his risk assessment in each individual case and/or for the respective activities. Generation Hire & Sale recommend the use of collective fall protection methods as detailed in NASC appendix SG4 where collective protection can be achieved.

Measures are to be selected based on the actual risk present, the purpose and practical possibilities and depending on the following basic conditions:

Qualification of the employees

Nature and duration of the activity in the hazardous area

Possible falling from height

Appearance of the surface on which the employee may fall

Appearance of the workplace and access

Technical and personal related measures are used for assembly, refitting and dismantling of the ALTRAD Futuro modular system. Possible measures for avoiding risks can be:

use of an assembly safety guard rails (AGR)

use of personal protective equipment against falling (PSAgA); or

a combination of both of the above-mentioned.

Use of AGR or PSAgA may be dispensed with in individual cases if the AGR and PSAgA do not offer adequate protection based on structural and scaffold specific circumstances.



There is a risk of falling when assembling, refitting or dismantling the futuro scaffold.



Define measures against the risk of falling by means of a risk assessment.

Assembling Further Scaffold Lifts

Temporary Tilt Protection of the First Scaffold Layer

When assembling the scaffold there may be the risk of tilting on the first layer in the bay in which vertical transport is carried out. A remedy can be provided by supports or anchoring in the area of the cover (2m).

Scaffold Assembly

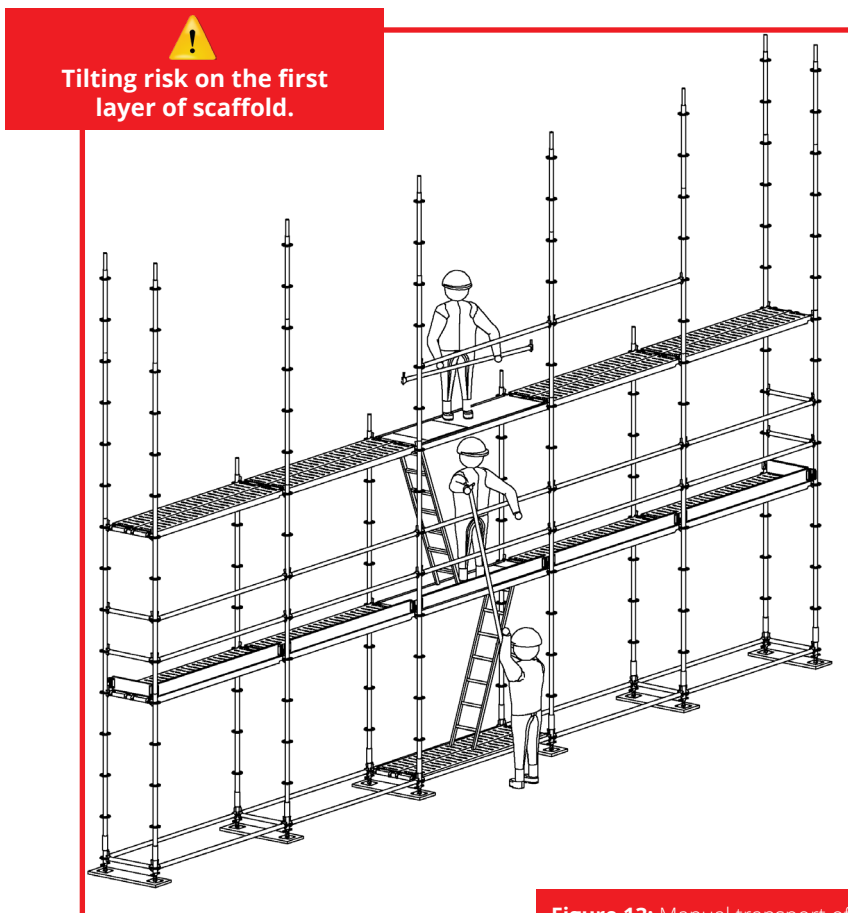

Figure 13: Manual transport of the scaffold components.

Assembling Further Scaffold Lifts

Assembly of the Vertical Standards and Horizontal Transoms

Depending on the height, the posts protrude either 1m or 3m in the top level. Horizontal transoms are fitted as side protection 1m in height over the whole scaffold length and on the end faces, as the first measure. The end façade side posts (figure 14) and/or the external posts extending beyond 1m are then lengthened in accordance with the requirements of the planned scaffold height and the support transoms fitted at a height of 2m (figure 14).

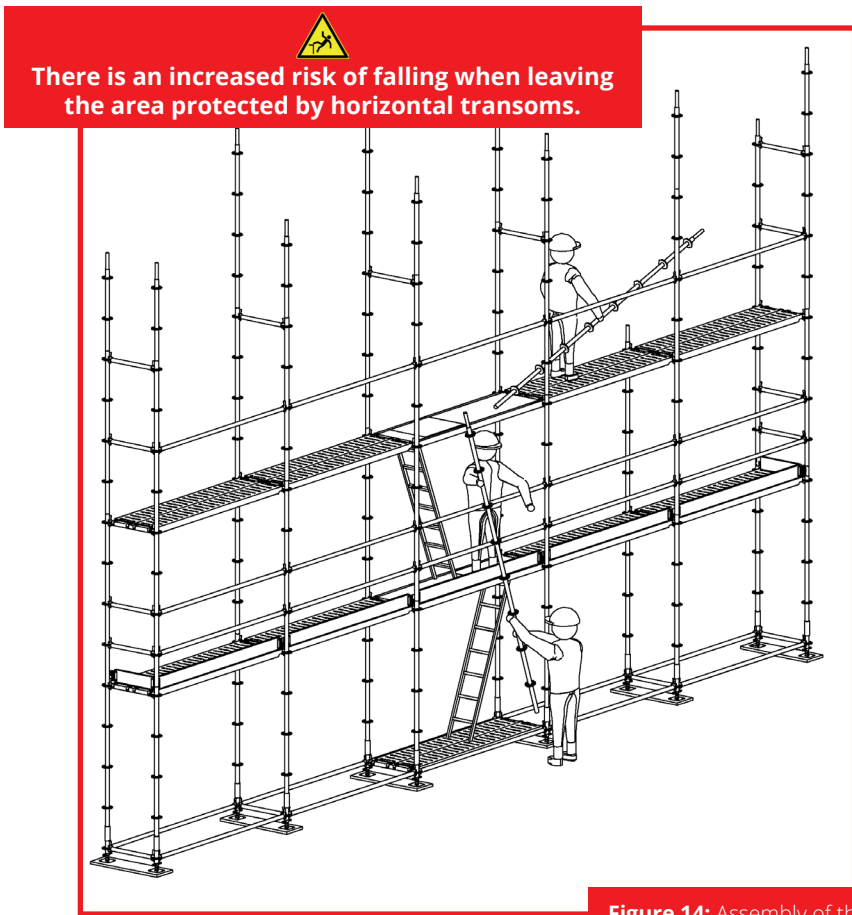

Figure 14: Assembly of the vertical standards.

Assembling Further Scaffold Lifts

In the next step, horizontal transoms are to be assembled as joint transoms. Since these stabilise the scaffold parallel to the facade together with the rail bars, both must be fitted in the upper level before leaving the site. Finally, the scaffold level is to be provided with toe boards and decks are to be placed over the levels.

As a rule, 4m long standards are to be fitted in the bottom region. The lengths of the standards are to be selected corresponding to the planned scaffold height in the head region.



Assemble joint transoms shortly after the rail transoms. The scaffold is stabilised as a result.

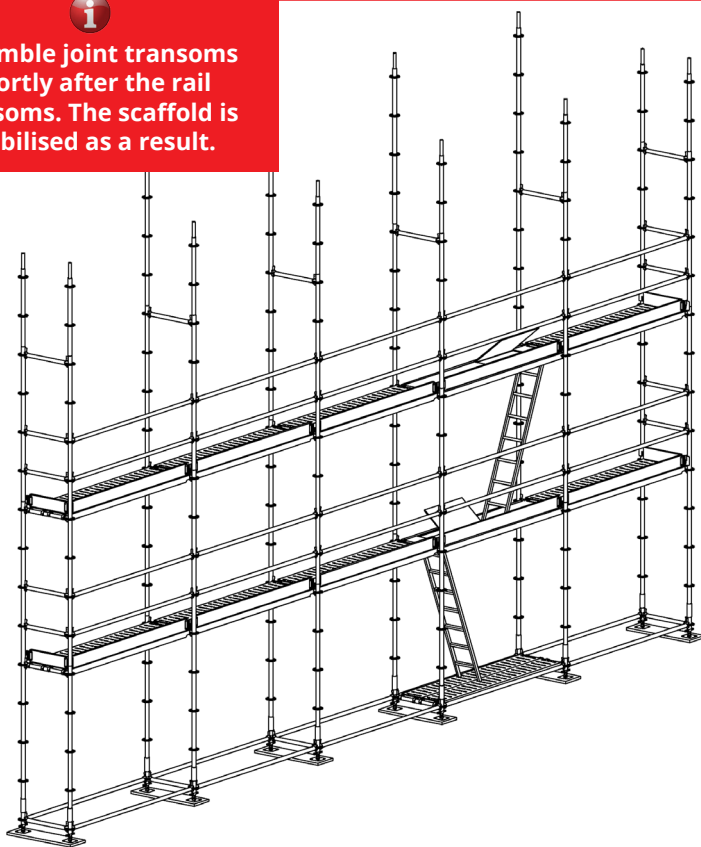

Figure 15: The second scaffold level.

Assembling Further Scaffold Lifts



The post butt joints are arranged on the façade side at the height of the deck, on the outside and on the end faces they are arranged 1m above the decks.

= Post butt joint

(Deck and side protection are not shown in figure 16. No longitudinal transoms are necessary at the level of the deck).

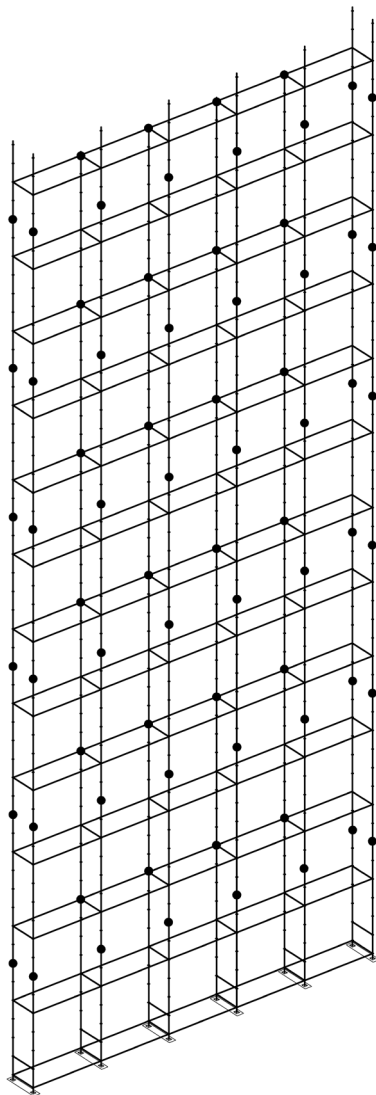

Figure 16: Position of the post butt joints.

Assembling Further Scaffold Lifts

Assembly of the Decks

The decks are to be fitted corresponding to page 26

Scaffold Ascent

Before starting the work on the first scaffold lift, the scaffold access should be fitted. This is an internal ladder on the ALTRAD Futuro modular system, which is made out of aluminium step through frames with integrated ladder. When assembling the openings, these are to be arranged offset (figure 15) and the flaps are to be closed each time one steps through. Under no circumstances may the flaps be raised or locked by over bending the opening angle or other measure. If the flaps are not locked after stepping through, there is a risk of falling into the opening.

Braces

Bracing (vertical diagonals) are not required for the standard type. Stiffening of the scaffold parallel to the façade takes place exclusively by the horizontal ledgers of the side protection.

Completing the Side Protection

Missing side protection ledgers and toe boards and the complete side protection on the end faces of the futuro scaffold are to be fitted in all scaffold layers which are not only used for the assembly of the scaffold. Double longitudinal transoms in each level are always necessary, even at levels which are not planned for work.

The toe boards are on steel panels. The decks are clamped between the wedge and standard tube.



Assembling Further Scaffold Lifts

Assembly Safety Guard Rails

General

There is a risk of falling, when ascending to the top scaffold layer and during subsequent assembly of the posts and transoms. As a measure to avoid risks when ascending to the first scaffold lift, it is recommended to use the assembly safety guard rails (AGR) as protection in the area of ascent. If a post coming from below, is not available in the area then the fitter can hold onto the AGR posts. The transom offers local side protection for the first post and the horizontal ledger (rails).

The assembly safety guard rails are assembled before accessing the upper rail level from the level below. In order to exclude a risk during assembly of the AGR, the complete 3 part side protection is to be fitted in this bay beforehand.

Description of the Assembly Safety Guard Rail

The design is described with lockable posts and telescopic guard rail. The assembly safety guard rails consist of individual posts and telescopic guard rails (see figure 17). Two posts and one rail are required for the first bay, for each further bay, one post and one rail.

Recommendation

Use assembly safety guard rails (AGR) in the area of ascent. Safety when climbing.



Generation's own hop up bracket system can also provide a temporary platform to enable advanced handrails to be fitted. If this is used a temporary ledger must be installed at platform level and removed once the permanent decks have been placed.

Figure 17: Assembly safety guard rails

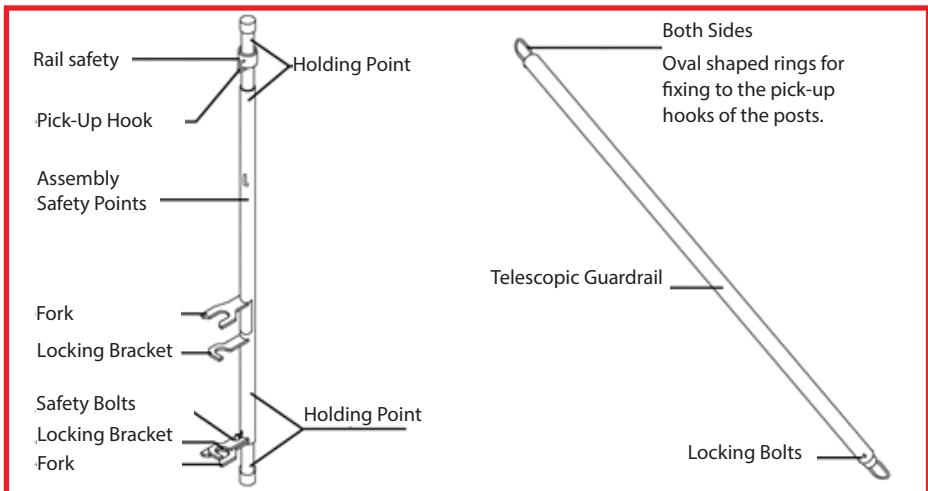

Assembling Further Scaffold Lifts

The posts consist of an outer and inner tube. The forks and hooks for the telescopic guard rails are fixed to the inner tube, the locking bracket to the outer tube. The rail retainer is freely moveable and pushed over the inner tube (see figure 17). The lower locking bracket has a hole, which sits on the bottom fork in the locked position via a safety bolt.

Assembly of the Advanced Guardrails

The posts are assembled externally before the standard tubes. They may be handled from above and below. In the event of assembly at height, they are released above by lifting (unlocking the locking bracket) and turning the outer tube clockwise (figure 18, step 1 and 2) and fitted 2m higher so that the bottom fork is on the wedges of the rail horizontal transom at approx. 1m height above the standing level.

For closing, the outer tube is turned anti-clockwise and lowered so that the bottom locking bracket is pushed over the safety bolt (figure 18, steps 3 and 4).

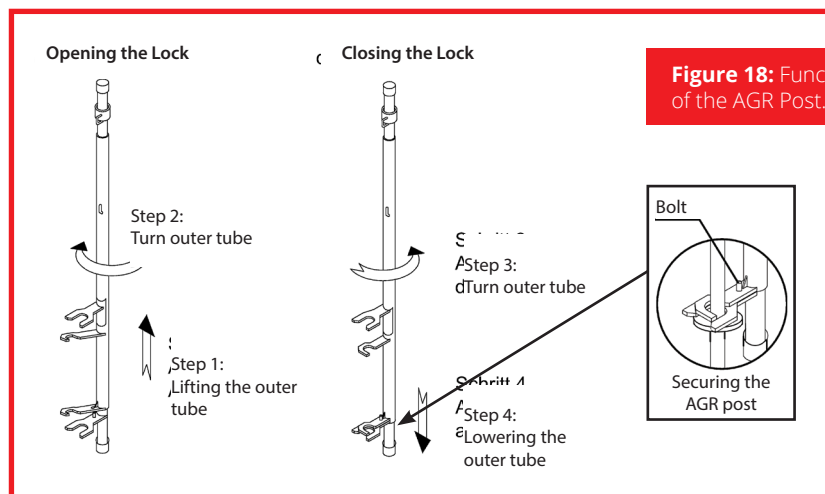

Figure 18: Functions of the AGR Post.

Upon initial assembly of the posts, the telescopic guard rails are pushed over the hooks where they remain until the end of use.

The safety sleeve prevents this from unintentionally falling out.

The telescopic guard rails are placed in position with the posts, from one level to the next. Both the horizontal and diagonal length of the ascending bay are covered.



Whilst assembling the Advanced guardrail there is an increased risk of falling.

The complete 3 part side protection is to be fitted in this area.

Assembling Further Scaffold Lifts

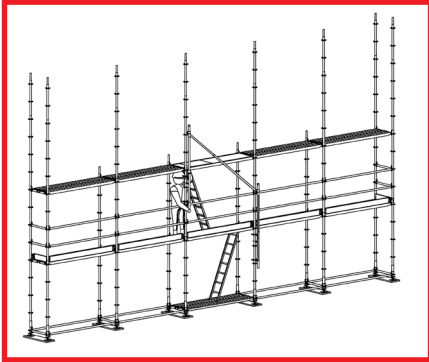

Figure 19: Constructing the first post at height.

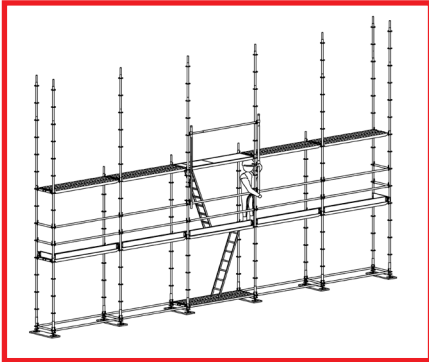

Figure 20: Constructing the second post at height.

Advanced guardrail over the whole length

When assembling the top scaffold layer the top scaffold layer can be temporarily secured with the assembly safety guard (figure 20a)

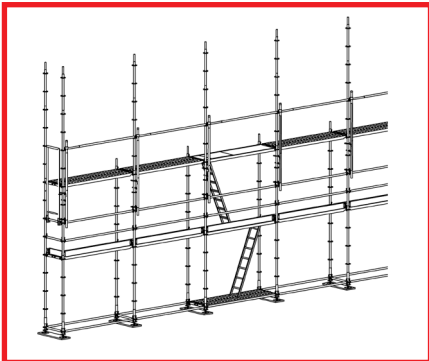

Figure 20a: Temporary securing of the upper layer with advanced guardrail.

Anchoring / Ties

Anchor Grid and Anchoring Force

The anchoring forces are those revealed for the installation variants. They represent “working loads”.

The loads per anchor at right angles (I) to the façade; are revealed parallel (II) to the façade every triangular bracket (as a rule every 5 bays).

Anchors are to be continuously fitted throughout the scaffold construction. Screws are to be used of at least 12mm in diameter or similar design as fasteners.

The scaffold brackets are to be designed in accordance with section 2.4.4.2. All scaffold brackets are to be connected with standard couplers diameter 48mm. These must be marked with a test symbol or in accordance with EN 74: 1988-12 and EN 74-1:2005-12 and the requirements fulfil the coupler class B.



The anchoring force is revealed as “working loads”. These are to be multiplied by 1.5 for proof of the force applied to other components.



The last anchor must lie either in the top level or one level below.

Scaffold Brackets

Short scaffold brackets (figure 21) are only fixed to the façade side of the vertical standard. They absorb the anchoring force at right angles to the façade.

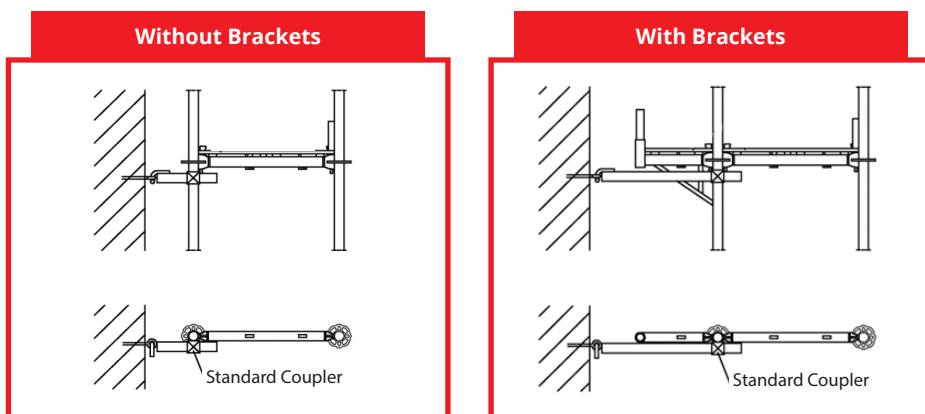
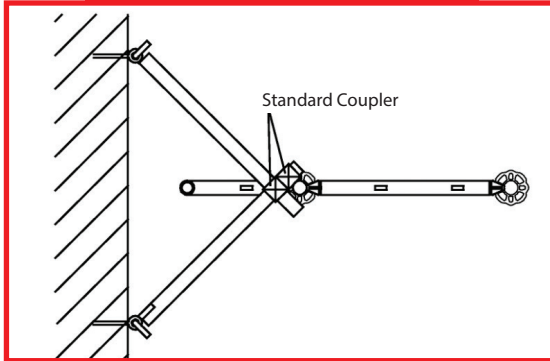

Figure 21: Short scaffold brackets

Anchoring / Ties

Triangle brackets (figure 22) are only fixed on the façade side of the vertical standard. They absorb the anchoring force at right angles and parallel to the façade.

With & Without Brackets



The picture applies to the U support and for tube supports.

Figure 22: V Bracket

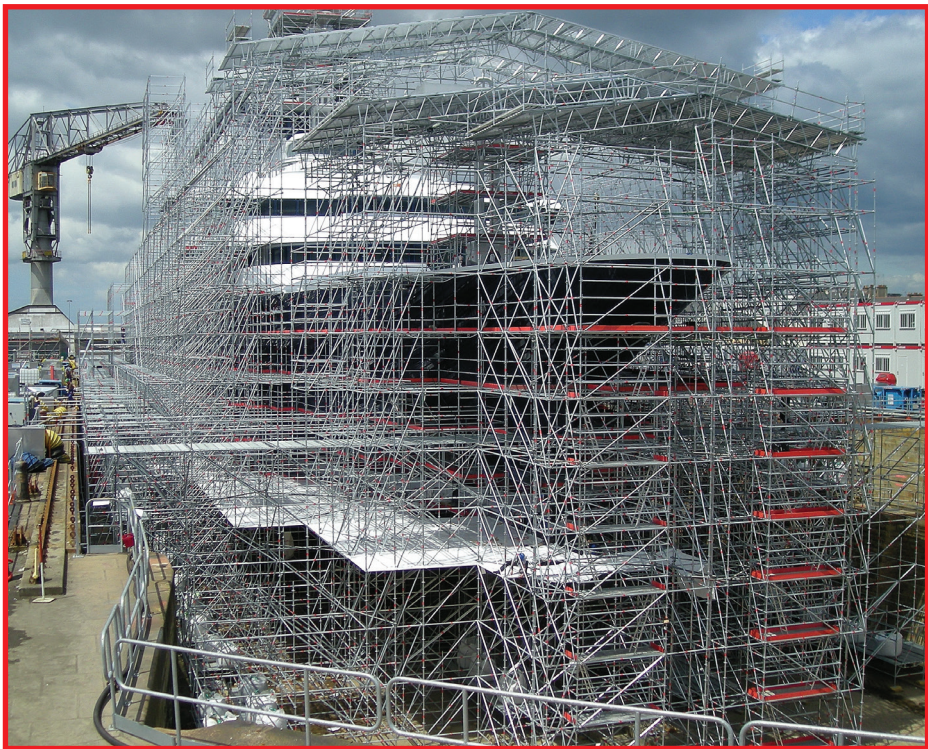

Applying the Anchoring Force in the Anchoring Base

The anchoring force must be initiated via the scaffold bracket (section 2.4.4.2) and fasteners in an adequate load bearing anchoring base (e.g. masonry).

The bearing capacity of the fasteners between scaffold bracket and anchoring base must be proven for the anchoring force.

Test Loads of the Anchors

Testing must be carried out to NASC TG4:11

Regular examination of ties for weathering and cracking, deformation or damage.

Pull out test must be performed by approved persons in accordance with the following criteria:

The pull out test load should be at least 1.25 x working load

Minimum of 3 ties and 5% of all ties is to be tested

Pull test results are to be documented and stored for the duration of the service life of the scaffold.



Assessment of the anchoring base and bearing capacity of the fasteners only be a qualified person.



Performance of test loads and assessment of the results only under the supervision of a qualified person.



Assembly Variants & Installation of Additional Components

General

The calculated assembly variants and assembly of supplementary components such as brackets, roof scaffold and bridging girders of the ALTRAD Futuro modular system are described as façade scaffold in this section. The maximum standing height is 24m plus the adjustable base length of the threaded base plates. The standard design is proven for working on just one scaffold level.

The necessary anchor distances are dependent on the wind permeability of the façade. They are shown as regular grids. The scaffold frames should always be anchored at a vertical distance of max. 4m.

Basically, a distinction is made between a “closed” and a “partly open” façade. The following applies to the design variants shown:

A “closed” façade does not reveal any openings whilst the “partly open” façade may consist of up to 60% of the surface area being open. With a larger open section, the anchoring must be proven in individual cases. For standard renovation work (windows remain in place) a “closed” façade” can be assumed. In the event of major conversion work (windows replaced) and new builds, a “partly open” facade is to be expected.

The decks act as stiffening elements of the ALTRAD Futuro modular system as façade scaffold. All work levels must be completely covered (see 2.2.5). Levels on which work is not carried out can be stabilised with internal and external horizontal transoms and at least one horizontal diagonal for every 5 scaffold bays.

Assembly Variants

Basic configuration (generic design - without brackets or other accessories), $L < 3.07\text{m}$

Bracket configuration (generic design with side brackets), $L < 3.07\text{m}$

U Support and Tube Support figure 23

Basic Configuration and Bracket Configuration
with protective wall, $L < 3.07\text{m}$
(U support and tube support) figure 24

Scaffold with bridging girder $L < 6.14\text{m}$
(U support and tube support) figure 25

Assembly Variants & Installation of Additional Components

Scaffold Before Closed or Partly Open Façade

**Basic Configuration
- Without Brackets**

**Basic Configuration
- With brackets
0.36m inside in each
layer**

Figure 23

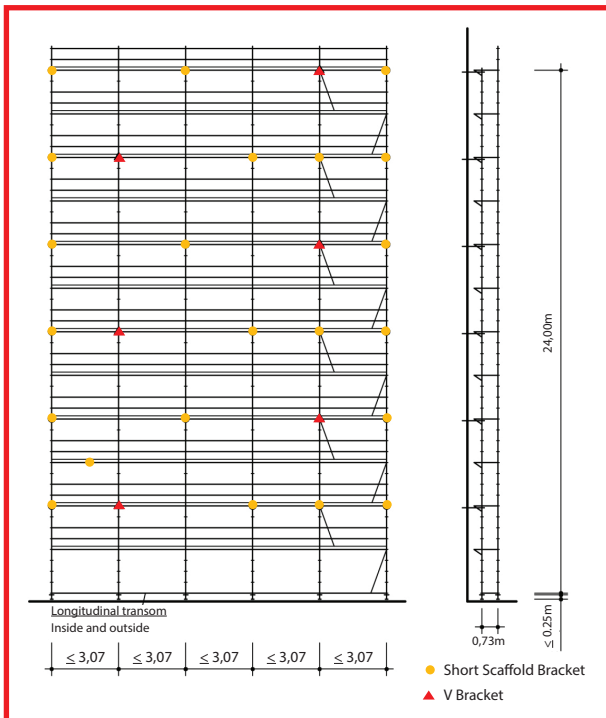
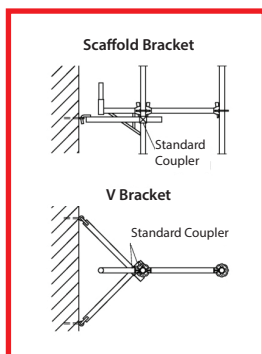

Façade			Closed		Partly Open		
Anchor Grid			8.0m displaced		8.0m displaced		
Additional Anchor			---		---		
Max. adjustable base extraction length (mm)			250		250		
Anchoring Force (kN)	Anchor height (m)		H ≤ 20	H = 24	H ≤ 20	H = 24	
	V-Bracket	⊥ to the façade	F ⊥	1,4	1,1	4,0	3,2
		to the façade	F	5,5		5,5	
		Angular load	Fa	3,9	3,9		
Foundation load (kN)	Inner post	Fi	15,5		15,5		
	Outer post	Fa	12,0		12,0		

Assembly Variants & Installation of Additional Components

Scaffold Before Closed or Partly Open Façade

Basic Configuration
- Without Brackets
- With Protective Wall

Basic Configuration
- With brackets 0.36m
inside in each layer
- With Protective Wall

Figure 24

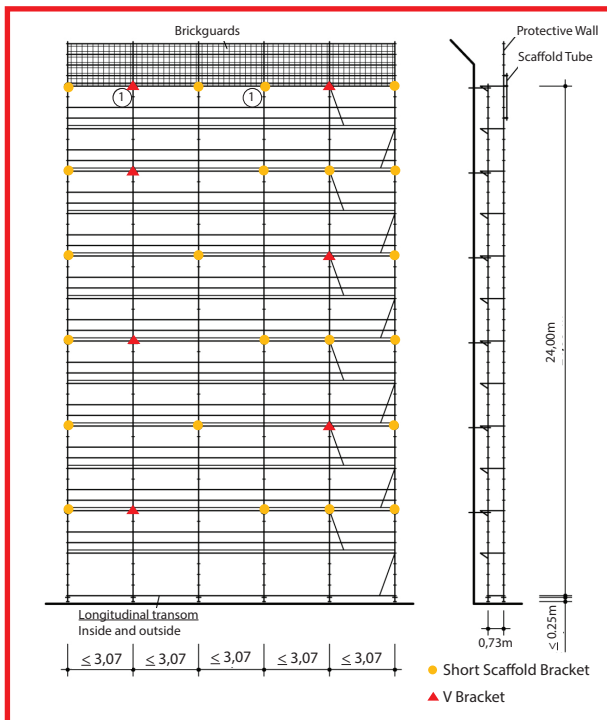
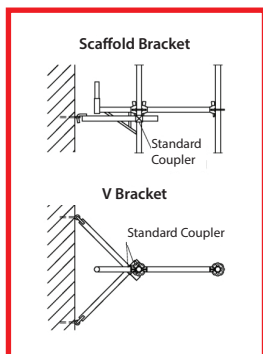

Façade			Closed		Partly Open		
Anchor Grid			8.0m displaced		8.0m displaced		
Additional Anchor			⓪		⓪		
Max. adjustable base extraction length (mm)			250		250		
Anchoring Force (kN)	Anchor height (m)		H ≤ 20	H = 24	H ≤ 20	H = 24	
	V-Bracket	┘ to the façade	F┘	1,4	2,2	4,0	3,4
		└ to the façade	F└	5,5		5,5	
		Angular load	Fa	3,9	3,9		
Foundation load (kN)	Inner post	Fi	15,5		15,5		
	Outer post	Fa	12,0		12,0		

Assembly Variants & Installation of Additional Components

Scaffold with Bridging < 6.14 m

Lattice girder H50 or bridging girder (L < 6.14 m)

Basic or Bracket Configuration

Assembly, see corresponding variant

Figure 25

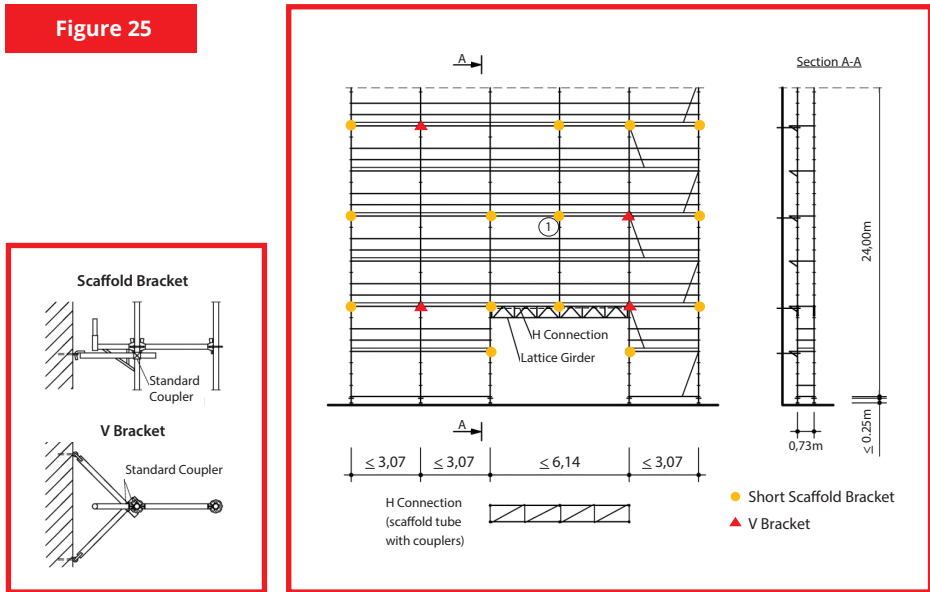

Facade			Closed	Partly Open	
Anchor Grid			8.0m displaced	8.0m displaced	
Additional Anchor			⊙	⊙	
Max. adjustable base extraction length (mm)			250	250	
Anchoring Force (kN)	Anchor height (m)		See Corresponding Configuration		
	V-Bracket	⊥ to the façade			F ⊥
		to the façade			F
		Angular load	Fa		
Foundation load (kN)	Inner post	Fi	22.1	22.1	
	Outer post	Fa	18.6	18.6	

Assembly Variants & Installation of Additional Components

Assembly of Supplementary Components

The extension brackets 39 and 42 may be fitted on the façade side with the bracket variants at any level. This applies to U support and to the tube support. They bear a 320mm wide scaffold deck which is to be fitted from the level below. If no bracket extension is available here, then there is a risk of falling.

The gaps between the scaffold and bracket deck is to be bridged with a horizontal ledger (see figures 11 & 12).

Dismantling the Altrad Futuro Modular System as Façade Scaffold.

The sequence of order of the work stages described in section 2.2 to 2.5 is to be reversed for dismantling the futuro scaffold. Anchoring may only be removed if the scaffold layer is completely dismantled. Components, the connection of which is loosened are to be immediately dismantled.

Dismantled scaffold components should not be stored on circulation routes to avoid the risk of persons tripping up. Dismantled scaffold components may not be thrown off the scaffold.

Use of the Altrad Futuro Modular System as Façade Scaffold

The futuro scaffold as façade scaffold in accordance with approval Z-8.22-841 may be used corresponding to load class 3 in consideration of these assembly and use instructions and in accordance with the stipulations of the Health and Safety at Work Act 1974, Construction Regulations Safe Place of Work Act 1996 and the Work at Height Regulations 2005 as work and protective scaffold without further proof. Other configurations with other load classes are possible. The stability is to be proven in individual cases as the basis of the approval.

The user of the scaffold must check the suitability of the selected assembly variants of the Futuro frame for the work to be performed and the safety function. He should ensure that the scaffold is inspected before use to determine any apparent defects. If defects are noted when checking, the scaffold should not be used in areas with defects until these have been remedied by the scaffold contractor. Subsequent changes to this scaffold are considered its installation, conversion or dismantling and may only be carried out by suitably qualified employees. They are to be checked and approved by the scaffold contractor.

Tests are to be repeated in extraordinary circumstances e.g. long period of non-use, accidents or acts of God having an effect on the scaffold.

Altrad Futuro Birdcage Scaffolds

General

The details in chapters 2.2 to 2.4.3 are applicable in the design of the façade scaffold. Since birdcage scaffolds do not normally protrude over a façade, it is not held horizontally by a standard anchor grid. Provided an anchoring facility exists, the concentrated points are on the building constructions to be fitted or structures nearby (as a rule in industrial construction). Based on the mostly large surface area, indoor scaffold can stand completely open. In all cases vertical diagonals are necessary in two crosswise directions for stabilisation (figure 26). Under certain circumstances, horizontal diagonals must be arranged as well. With the design shown in figure 26 this may be dispensed with. The deck level designed as a plate takes over the stiffening of the scaffold in this process.

A tried and tested standard design is revealed for the facade scaffold type which is shown in approval Z-8.22-841, Appendix C and in these assembly and instructions for use, figures 23 to 25. The definition of a standard design is not however possible for indoor scaffolds. It is therefore necessary to check the stability for each scaffold.

Simple statistical calculations can be carried out with the aid of the details in chapter 4. With larger and complicated scaffold constructions, the dimensional values revealed in approval Z-8.22-841 chapter 3 and appendix A are to be taken into consideration.

The work levels of the ALTRAD Futuro modular system can be formed from system decks of the façade scaffold quadro 70 or decks with round tube support claws. Furthermore, construction with system-free steel or wooden transoms is possible. The various designs with the associated components are described in the following chapters in detail.

The components not belonging to the standard design as façade scaffold are included in appendix B of the approval Z-8.22-841. Their manufacture is governed in this approval.



Appendix A - Calculation rules and loading data for system scaffolding.

Appendix B - German Construction Approval Z-8.22-841

Appendix C - Façade scaffolding solution (73cm wide).

Appedicies available on request from Generation Design Dept.

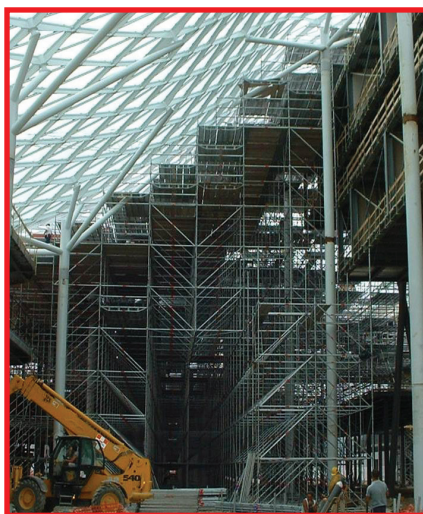

Altrad Futuro Birdcage Scaffolds

Figure 26: Typical Indoor Scaffold as Surface Scaffold (ascent not shown).

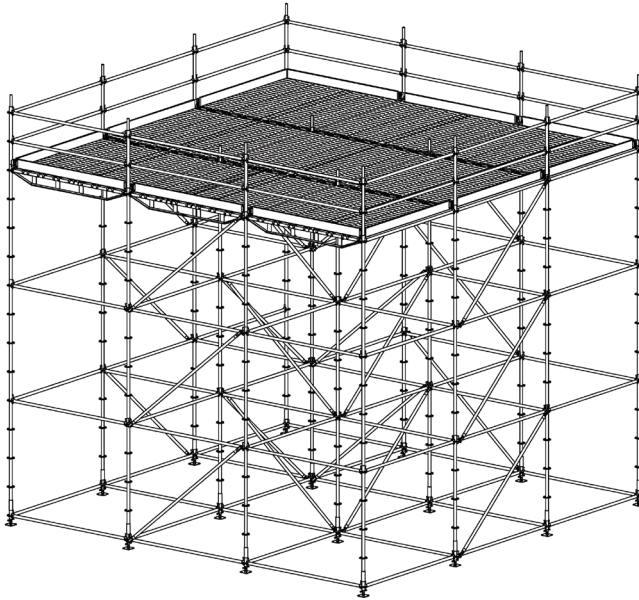

Design with Series Quadro Decks

General

In order to be able to use the decks of the façade scaffold quadro 70 the associated support transoms and brackets are provided with U profiles. The claws on the head parts of the panels are suspended in the sides facing upwards. The floor panels can be placed horizontally in the desired position. The components are to be fitted in accordance with appendix B as lifting safety retainers. These deck retainers are revealed for all girder lengths up to 3.07m.



**Appendix B - German Construction
Approval Z-8.22-841
Appedicies available on request from
Generation Design Dept.**

Design with Series Quadro Decks

Deck Transom U-Support - Sale Only

The simple U support transoms are planned for one to four deck plates 32.

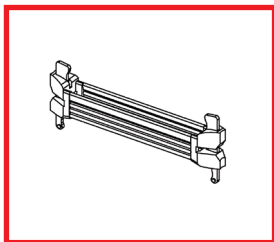

Axial dimension 1 beam = 420mm

Code: 519052

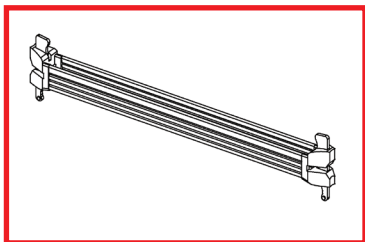

Axial 2 beam = 730mm

Corresponds to the width of
The vertical frame quadro 70

Code: 519053

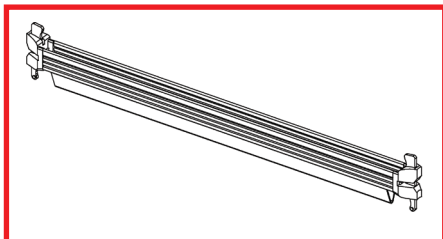

Axial dimension 3 beam = 1.09m

Corresponds to the width of
The vertical frame quadro 100

Code: 519055

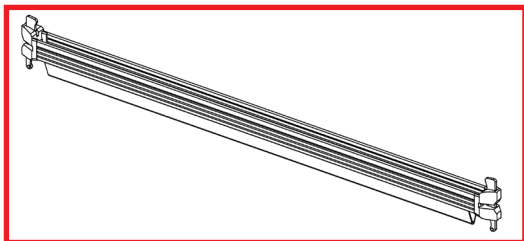

Axial dimension 4 beam = 1.40m

Code: 519056

Double Transom U-Support - Sale Only

190mm wide deck transoms are to be fitted as compensation floor panels on U support double transoms. The arrangement of the floor panels for the individual bay lengths is shown on the following pages in detail.

Design with Series Quadro Decks

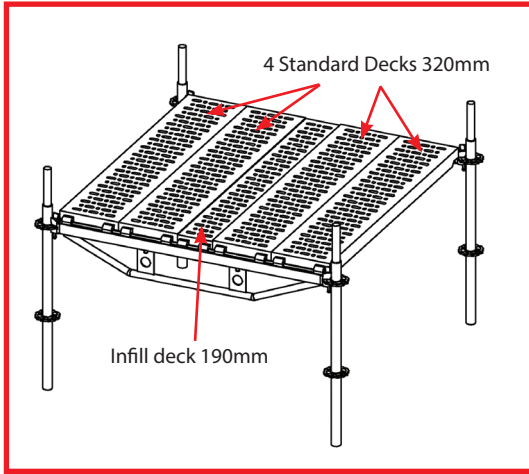

Figure 27: The 1.57m wide bay

The 1.57m wide bay consists of 4 standard decks 320mm and a 190mm wide deck floor panel. This may not lie up to the edge. It must be arranged between the 32' floor panels due to the small edge distance of the claws.

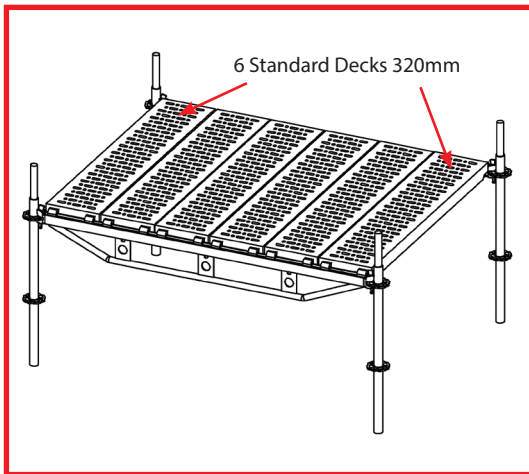

Figure 28: The 2.07m wide bay

The 2.07m wide bay consists of 6 standard decks 320mm.

Design with Series Quadro Decks

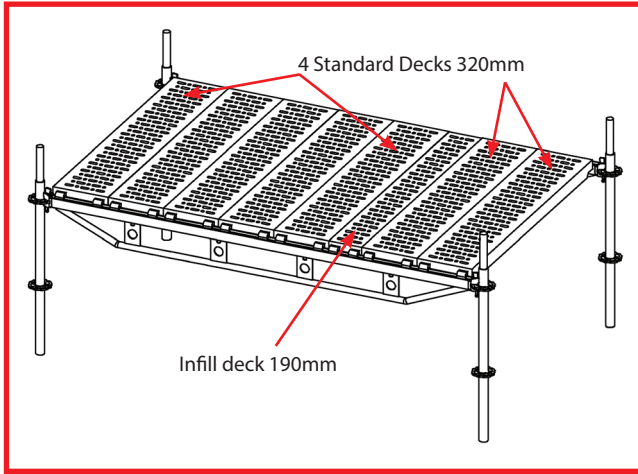

Figure 29: The 2.57m wide bay

The 2.57m wide bay consists of 7 standard decks 320mm and a 190mm wide deck floor panel. This can be arranged in this bay at any point.

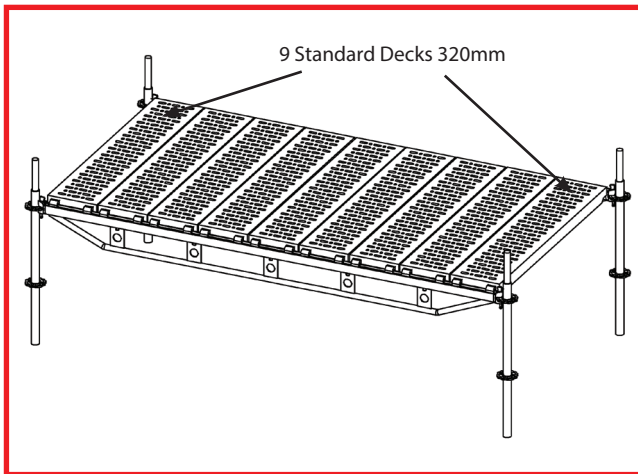

Figure 30: The 3.07m wide bay

The 3.07m wide bay consists of 9 standard decks 320mm.

Design with Series Quadro Decks

U-Lattice Girder with 4 Wedge Heads - Sale Only

The U-lattice girders with 4 wedge heads have a chord distance of 500mm. As a result both chords can be connected to the perforated disks. The top chord consists of a U profile, the bottom chord of a round tube diameter 48.3mm. Based on the double connection on each side of the standard tubes, the scaffold design in the lattice girder is stable enough so that further stiffening measures are generally not required.

Figure 31: Lattice Girder for U Support

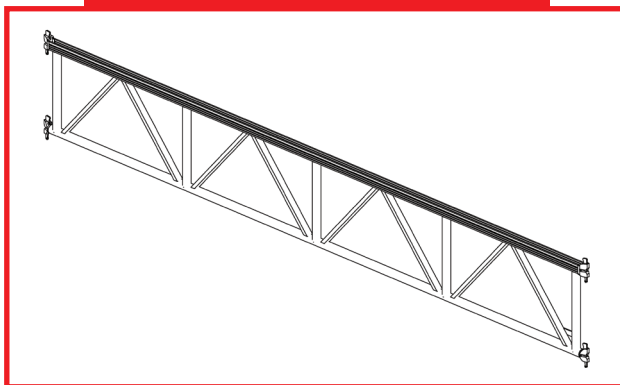

The covering of the lattice girder is the same as the double transoms with standard floor panels 320mm and individual compensation floor panels 190mm (see point 3.2.3). Their quantity is revealed in table 2.

The 190 deck panels can be fitted at any point

Table 2: Covering of the U lattice girder

Girder Length (m)	Steel Deck 32 (part)	Steel Deck 19 (part)
2.07	6	0
2.57	7	1
3.07	9	0
4.14	12	1
5.14	15	1
6.14	18	1

Design with Series Quadro Decks

Support Transoms

The round tube transoms can be used up to a length of 1.57m as support transoms.

Figure 32: Round Tube Transoms

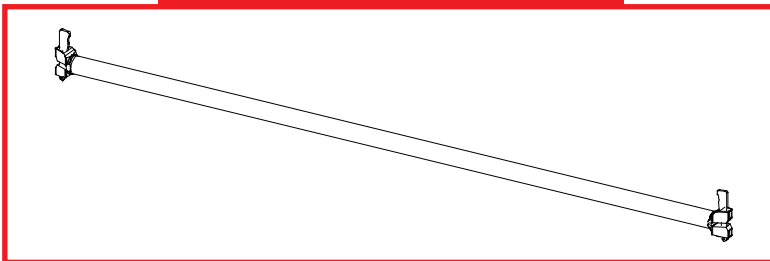

Transoms of a length 1.09m and 1.40m are produced for higher loads with reinforcement made out of a T profile. Locking of the lifting safety devices to the floor panels is not hindered in this way. A large as possible head room is enabled based on the structural height of only 88mm.

Figure 33: Support Transom, 109, Reinforced

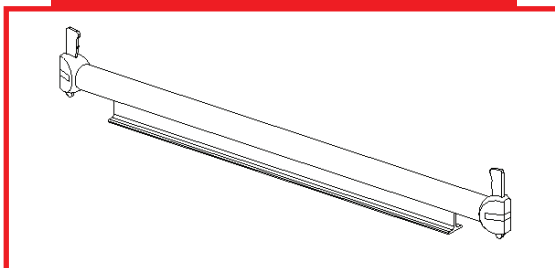

Lengths 1.57m, 2.07m, 2.57m and 3.07m are designed as double ledgers. The design is adapted to the higher loading requirements.

Figure 34: Double Ledger for Tube Support

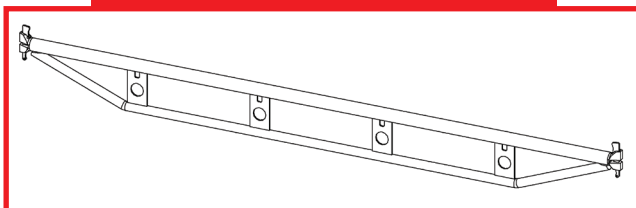

Design with Series Quadro Decks

Lattice Girder with 4 Wedge Heads

The lattice girders for tube support have a system height of 500mm and are connected to the disks of the standard tubes with the top and bottom chords. The scaffold construction is very stable at the level of the lattice girder. Further stiffening measures are not necessary as a rule.

Figure 35: Lattice girder for tube support.

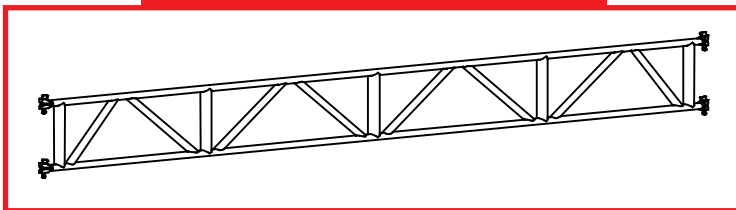

Lengths of 4.14m, 5.14m and 6.14m are produced. Three 32 decks per metre supplied are fitted. In addition, a 19 compensation floor panel is required per girder.

Arrangement of the Decks

The arrangement of the round tube decks can take place as with the U tube depending on the length of the transom in accordance with table 3.

Table 3: Covering of the support transom and lattice girder

Transom Length (m)	Deck Plate 32 (part)	Deck Plate 19 (part)
0.42	1	0
0.73	2	0
1.09	3	0
1.40	4	0
1.57	4	1
2.07	6	0
2.57	7	1
3.07	9	0
4.14	12	1
5.14	15	1
6.14	18	1

Design with Series Quadro Decks

Brackets

Brackets for round tube support are available with 1 deck and 2 deck system width (figure 36) i.e. for one or two deck plates. The brackets are designed in such a way that they can be applied horizontally below 90° to a standard (corner solution).

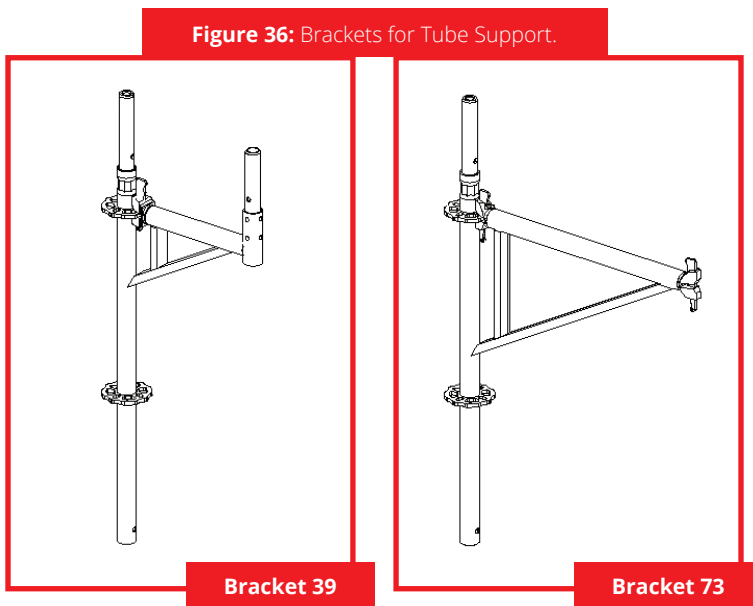

Bracket 39 reveals a welded tube connector. A vertical post can be connected directly as a rail post.

Brackets 73 are provided with a connection head on the top to which a vertical post can be connected if required. Post 116 is recommended as the rail post.

If one wishes to fit something else to bracket 73 above, one or two vertical diagonals can be used as bracing in addition with design 73 * 200.

One or two steel decks can be used for the variable bracket. The wedge head is to be reset with the welded tubular part from one support tube to another and fixed with bolts. Figure 37 on the left shows the arrangement for a deck (bracket 39) and on the right for two decks (bracket 73).

Design with Series Quadro Decks

Figure 37: Adjustable bracket 39/73 (tube support)

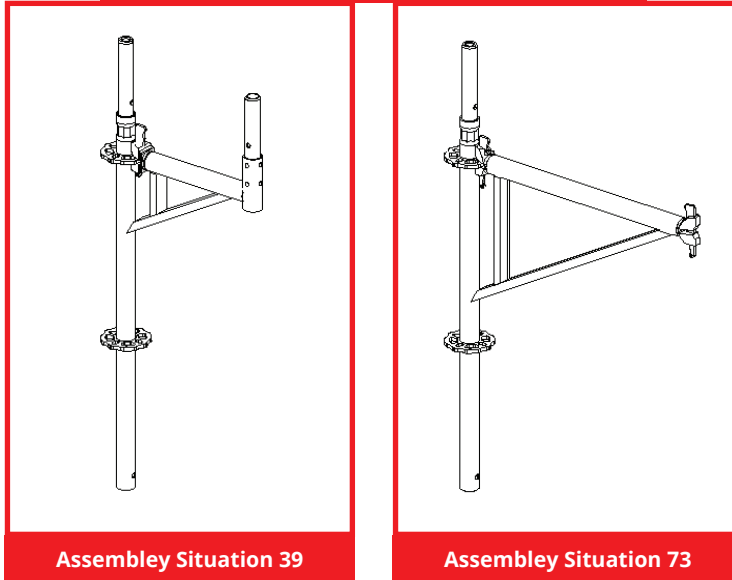

Arrangement of the Decks

The toe boards are to be provided with slits. These are pushed in behind the wedges of the support transom. The toe boards are located on the edge of the decks (detail 1). The slots are pushed into each other on the corners. In this process, one end is to be used with slit upwards and the other with slit downwards (or vice versa) (detail 2). The use of toe boards is as shown both for the U support and for the round tube support.

Figure 38: Aluminium Toe Board (viewed from the outside).

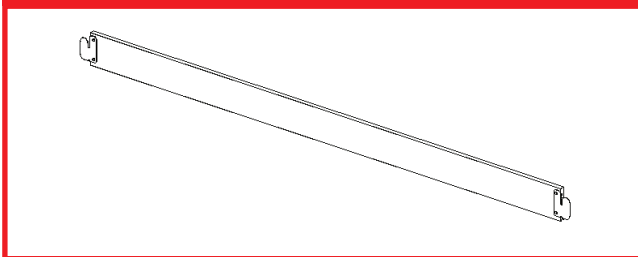

Design with Series Quadro Decks

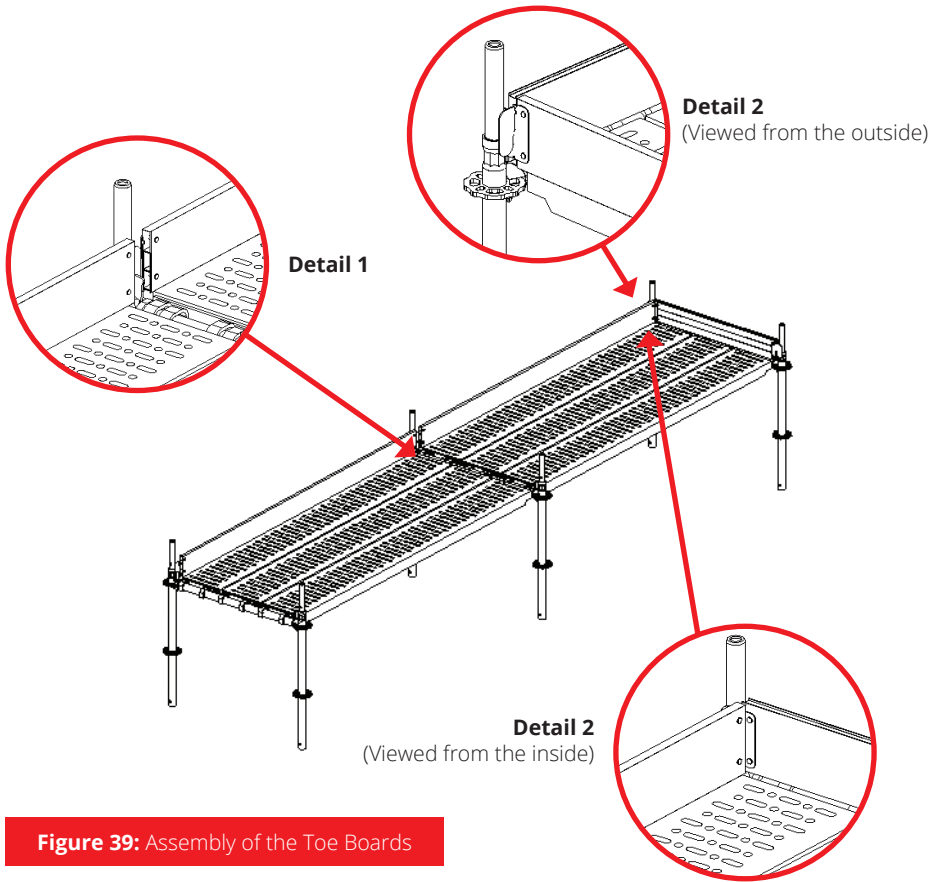

Design with Series Quadro Decks

Brackets for U-Support - Sale Only

Brackets for U-Support are available for one and for two steel decks. The deck mountings consist of the same U profile as the support transoms. The brackets are designed in such a way that they can be applied horizontally below 90° to a standard (corner solution).

Figure 40: Brackets for U-Support

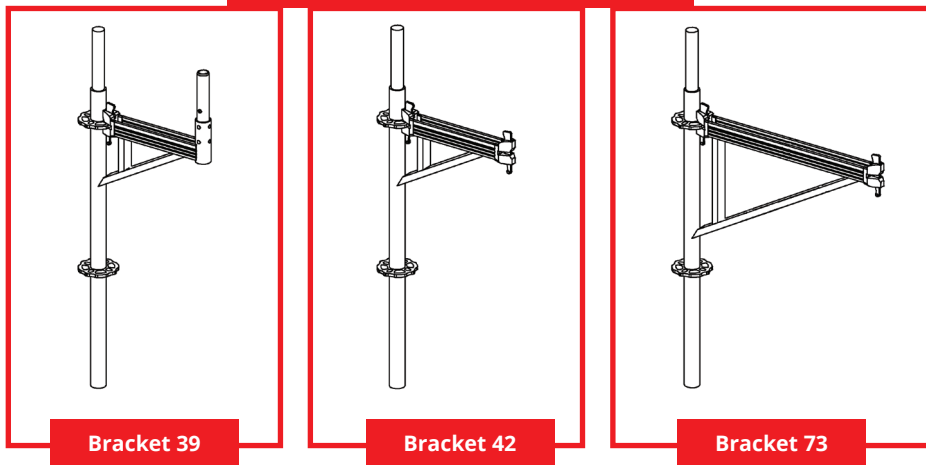

Bracket 39 reveals a welded tube connector. A vertical post can be connected directly as a rail post. Brackets 42 and 73 are provided with a connection head on the top to which a vertical post can be connected if required. Post 116 is recommended as the rail post.

If one wishes to fit something else to bracket 73 above, one or two vertical diagonals can be used as bracing in addition with design 73 * 200.

One or two steel decks can be used for the adjustable bracket. The wedge head is to be reset with the welded tubular part from one U profile to another and fixed with spring pin bolts. Figure 41 on the left shows the arrangement for a deck (bracket 39) and on the right for two decks (bracket 73).

Design with Series Quadro Decks

Figure 41: Adjustable Bracket 39/73 (U Support)

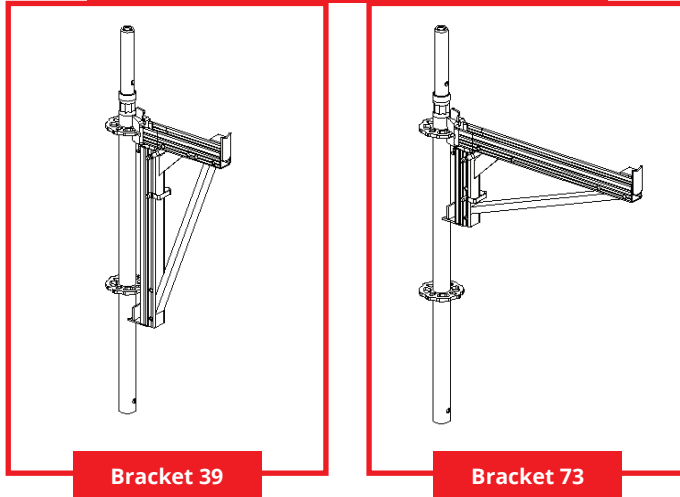

Deck Retainer and Toe Board - Sale Only

Deck retainers should only be fitted if lifting wind loads arise or the scaffold is to be stabilised by steel decks.

Figure 42: Deck Retainer

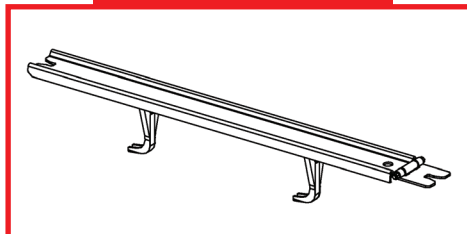

The deck retainers are to be provided with two hooks which are pushed from above through the holes provided for this purpose in the support transoms. The hooks grip below the U profile. After lifting up the hinge, the deck retainer is clamped between both standard tubes and can no longer be released.

The toe boards to be inserted in the U-Support are identical to those of the tube support.

Design with Series Quadro Decks

Decks

Steel deck panels with welded claws are used which are offset. Continuous laying is possible without side misalignments. The forged claws are of the old design and have bent plate claws. As with the floor panels for U support, the standard width is 320mm (figure 43) and the width of the compensation floor panels 190mm (figure 44). The tilting safety device prevents tilting of the floor panel when stepping on this on the corner on the claw turning inwards.

Figure 43: Steel Deck Panels with Forged Claws.

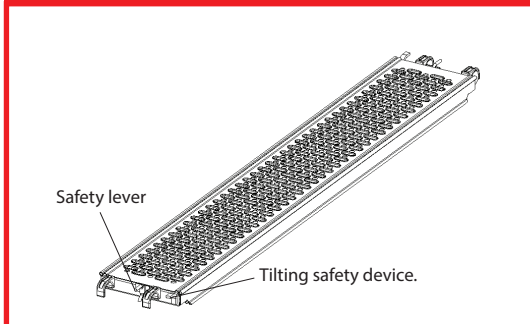

An integrated lifting safety device protects against unintentional lifting of the claws and lifting in the event of upward wind loads. The current design is such that the safety lever falls into the lock position automatically when fitting the decks. For safety reasons this can be inspected at all times. Based on the position of the upper side, it is easy to see whether the lifting safety device has closed or whether it is still

open. With the 32 floor panels with claws and the 19 floor panels, rotary levers are fitted under the head fittings with which the floor panels can be secured to prevent lifting up.

Figure 44: Steel Deck Panels 19 with Plate Hooks

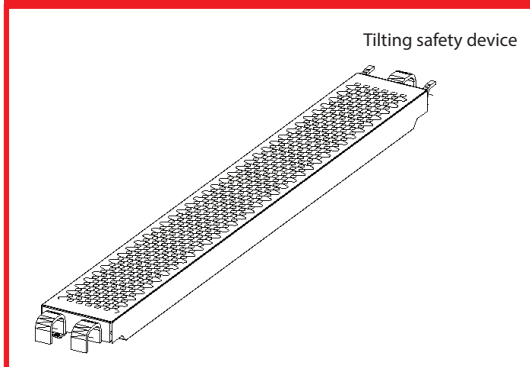

The current lifting safety devices are designed so that the safety levers automatically fall into the locked position when fitting the floor panels. One should always check whether the lifting safety devices have locked.

Altrad Futuro as Round Scaffolding

General

Based on 8 possible connections to the decks in large and small holes, round surfaces can be fitted without a problem.

A distinction is to be made between “small” and “large” diameters.

“Small” diameters (< 3.00m) can have e.g. piers or chimney stacks. A square design is chosen here.

“Large” diameters have e.g. oil tanks. Fitting of the curvature takes place horizontally.

Objects with Small Diameter

The round structure is surrounded by a square scaffold so that the main deck is at < 300mm distance from the outer surface (figure 44a). The transoms are connected to small holes so that they form a right angle (see junction detail).

The open internal corners are covered with system-free steel floor plates. These are to be secured against lifting up and sliding. Provided no fire protection conditions are to be observed, corresponding wooden boards can be used.

All four external levels are to be stiffened with face bracing.

Figure 44a

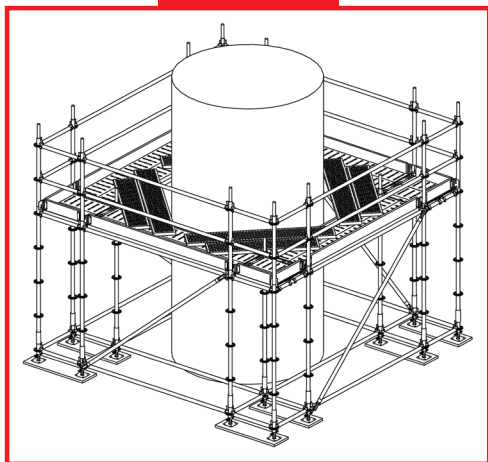

The floor plates are to be protected against lifting and sliding.

Connection to the small holes

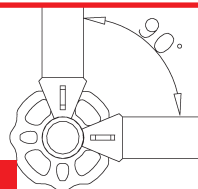

Junction Detail



The scaffold cell is automatically aligned so that it is square when connecting the transoms to the small holes.

Altrad Futuro as Round Scaffolding

Objects with Large Diameter

With larger diameters the scaffold must follow the curvature. Square cells are fitted and arranged at such a distance that the outer levels can be connected with series horizontal ledgers (figure 45). Since the connecting transoms cannot form right angles with the scaffold cells, the posts are to be turned so that all transoms are connected to the large holes. An angle of up to 30° is achieved between the scaffold cell and connection transom (see junction detail).

Figure 45: Lower Scaffold Level

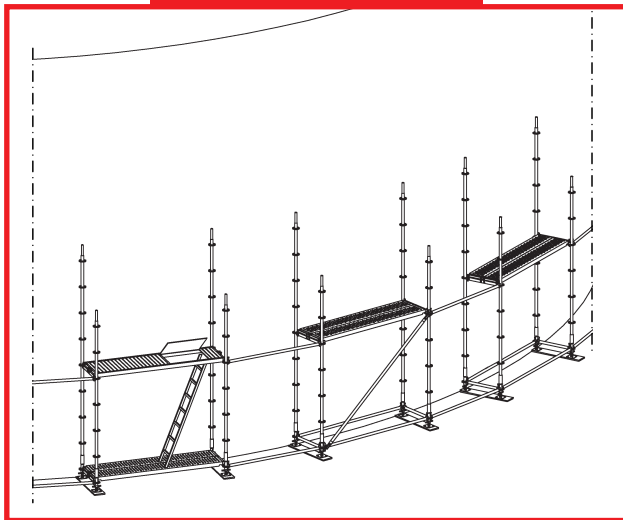

When connecting the transoms to the large holes deviating angles from 90° can be achieved between the transoms. Since the scaffold cells are no longer automatically aligned, perpendicularity must be ensured by other measures e.g. by aligning the diagonal dimensions.

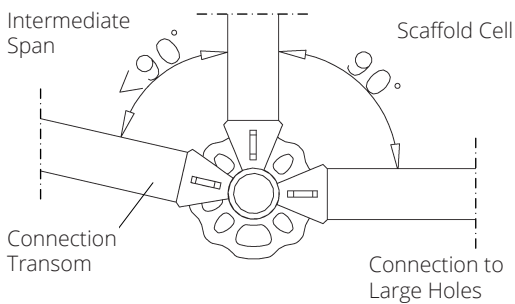

Junction Detail

Altrad Futuro as Round Scaffolding

Stiffening is to take place at least every 2nd scaffold bay (see text relating to figure 46) by means of vertical diagonals. The intermediate spaces are to be covered with system-free steel decks or where necessary with wooden boards (protected against lifting and sliding).

The description of the façade scaffold design is to be observed for assembly. The anchoring is to be continuous in accordance with figures 21 and 22. It should be checked whether overall the minimum rail height of 0.95m is present. If values fall below these a third horizontal ledger is necessary at +1.50m above the level of the support ledger.

Figure 46: Completed Scaffolding

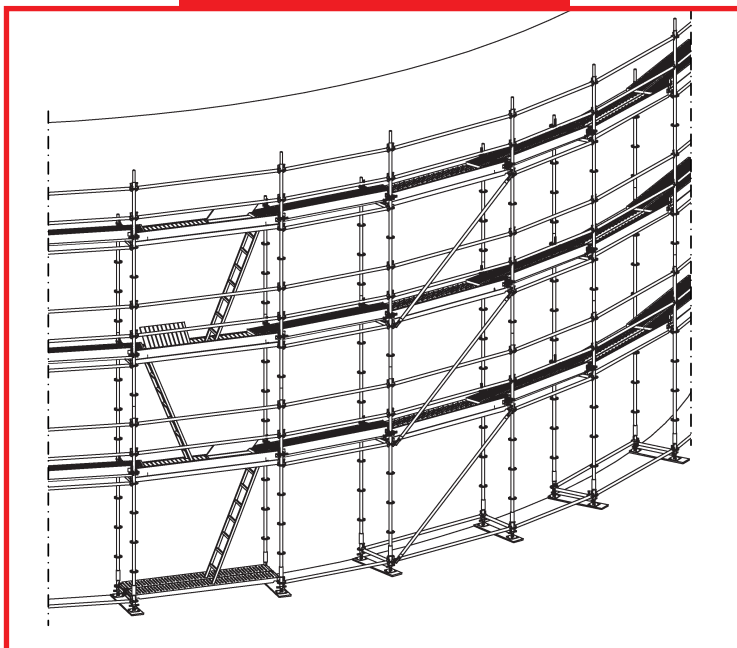

The floor plates are to be protected against lifting up and sliding. Values should not fall below the minimum rail height of 0.95m. A third rail girder is then necessary.

Capacity of Items

General

Loads mentioned in this chapter are safe working loads. That means that these loads may be applied without any further reduction. They shall give reference to the user to be able to roughly estimate the capabilities of a scaffold set up. The loads given are applicable for the components of "Version II" design.

For more detailed calculation the detailed loading data supplied separately by the manufacturer shall be taken into account. The detailed loading data contains the complete set of loading and spring stiffness of the components. They are third party controlled and stated in the German approval Z-8.22-841.

Ledgerhead

The most often used loading values are shown by little sketches. They shall only be taken into account in case that the junction is loaded without any other interaction.

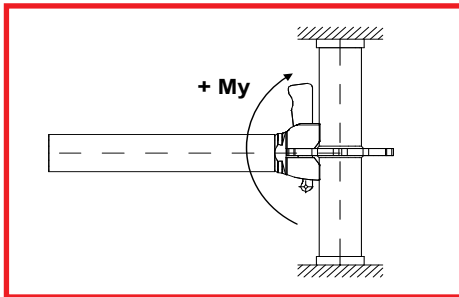

The bending moment M_y is the vertical cantilevering moment (Load * Distance).
Ledger: allowed $M_y = \pm 63.0 \text{ kNcm}$

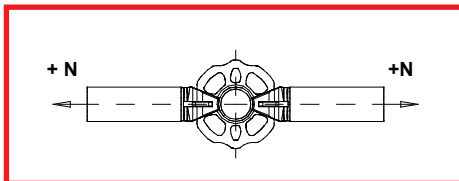

The normal load N is a tensile or compressive load along the axis of the ledger.
Ledger: allowed $N = \pm 20.2 \text{ kN}$

Capacity of Items

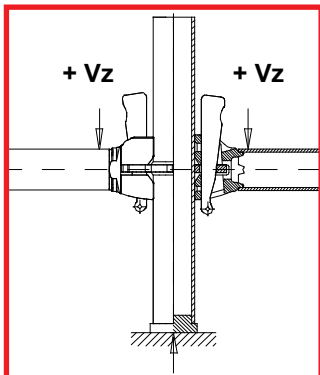

The vertical load V_z represents the load to be transferred vertically by the ledgerhead into the disk. The full value is only applicable in case that the load is applied just behind the head without any further influence from additional bending moments.

Ledger: allowable $V_z = \pm 17.3$ kN

In case that several ledgers are transferring loads into the same disk, The sum may not exceed:
allowable $\Sigma V_z = \pm 48.8$ kN

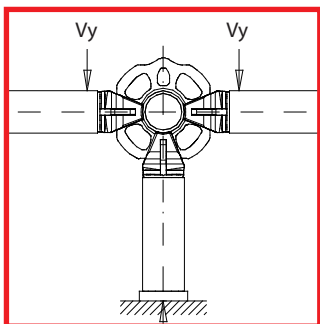

The horizontal load V_y represents loads from wind or other means to be transferred horizontally from ledgerhead into the disk.

Ledger: allowable $V_y = \pm 6.2$ kN

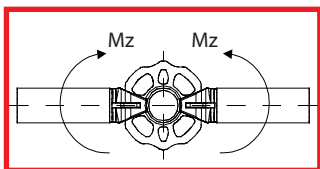

The bending moment M_z is the horizontal cantilevering moment (Load * Distance).

Ledger: allowable $M_z = \pm 14.5$ kNcm

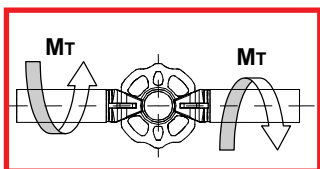

The twisting moment M_T represents resistance against twisting for ledgers connected into the junction.

Ledger: allowable $M_T = \pm 38.7$ kNcm

Capacity of Items

Vertical Braces

Vertical braces are reinforcing the scaffolding and are the key component for the stability of the entire scaffolding. The load to be transferred from brace to disk may not exceed: allowable $N_v = \pm 16.3 \text{ kN}$

In the case that this load is applied by tension all vertical braces will be able to transfer this load regardless of the length.

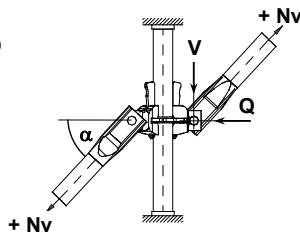

In the case that the load is applied by compression the axial stiffness of the tube becomes relevant. Table 4 contains the safe working loads for a single brace loaded by tension or compression (N_v). Also the horizontal (Q) and vertical (V) components of this load are shown. Note: In case that several braces are used to support a certain load the addition of the capacities is only allowed if all braces have the same length and all are loaded in the same way (all with compression or all with tension). In case that different braces are used or that the loading is differing (compression / tension) the max. capacity of the system has to be calculated by taking the resistance of the single components into account.

Table 4: Capacity of vertical braces (safe working load)

Bay Length (m)	α (°)	Loading by Tension			Loading by Compression		
		all. N_v (kN)	all. Q (kN)	all. V (kN)	all. N_v (kN)	all. Q (kN)	all. V (kN)
Bay Height H = 2.00m							
3.07	34.4	16.30	13.5	9.2	-4.98	4.1	2.8
2.57	39.6		12.6	10.4	-6.01	4.6	3.8
2.07	46.2		11.3	11.8	-7.39	5.1	5.3
1.57	54.7		9.4	13.3	-9.29	5.4	7.6
1.40	58.1		8.6	13.9	-10.10	5.3	8.6
1.09	65.0		6.9	14.8	-11.80	5.0	10.7
0.73	73.9		4.5	15.7	-13.87	3.9	13.3
Bay Height H = 1.50m							
3.07	27.2	16.30	14.5	7.5	-5.26	4.7	2.4
2.57	31.8		13.9	8.6	-6.32	5.4	3.3
2.07	38.0		12.9	10.1	-7.82	6.2	4.8
1.57	46.6		11.2	11.9	-10.01	6.9	7.3
Bay Height H = 0.50m							
3.07	9.7	16.30	16.1	2.8	-5.43	5.4	0.9
2.57	11.7		16.0	3.3	-6.39	6.3	1.3
2.07	14.6		15.8	4.1	-6.63	6.4	1.7
1.57	19.4		15.4	5.4	-7.03	6.6	2.3

Capacity of Items

Table 4: (continued) Capacity of vertical braces (safe working load)

Bay Length (m)	α (°)	Loading by Tension			Loading by Compression		
		all. N _v (kN)	all. Q (kN)	all. V (kN)	all. N _v (kN)	all. Q (kN)	all. V (kN)
Bay Height H = 2.00m							
3.07	18.9	16.30	15.5	5.3	-5.42	5.1	1.8
2.57	22.5		15.1	6.3	-6.46	6.0	2.5
2.07	27.5		14.5	7.6	-7.58	6.7	3.5
1.57	35.2		13.4	9.4	-8.67	7.1	5.0
1.54	35.9		13.2	9.6	-9.40	7.6	5.5
1.29	41.5		12.2	10.8	-9.87	7.4	6.5
1.09	47.0		11.1	11.9	-11.23	7.7	8.2

Plan Braces and Bracing Ledgers

For the plan braces with two ledger heads of non-symmetric bays the welding connection between the angled tube and the head is the limiting factor. The allowable capacity is shown below:

$$\begin{aligned}
 L = 2.07 * 1.09 \text{ m to } 3.07 * 1.57 \text{ m:} & \quad \text{all. N} = 7.33 \text{ kN} \\
 L = 3.07 * 2.07 \text{ m:} & \quad \text{all. N} = 7.07 \text{ kN} \\
 L = 3.07 * 2.57 \text{ m:} & \quad \text{all. N} = 6.00 \text{ kN}
 \end{aligned}$$

Bracing ledgers for symmetric bays are designed similar to common ledgers. The capacity can be taken from the loading data of a ledger taking the rigidity of the compressed tube into account. Table 5 contains safe working loads for bracing ledgers.

Table 5: Capacity of Bracing Ledgers

Bay Size (m*m)	Length (m)	all. Tension (kN)	all. Compression (kN)
1.57 * 1.57	2.223	20.2	20.2
2.07 * 2.07	2.930	20.2	12.7
2.57 * 2.57	3.637	20.2	8.5
3.07 * 3.07	4.344	20.2	6.1

Plan braces with pins at the ends (former design) do all have the same capacity: allowable N = ± 2.71 kN

Capacity of Items

Standards

The given values for allowable loading of vertical standards are just applicable for preliminary estimations. Supporting base jacks should not be extended more than 0.1m. Should the extension of base jacks be more or for the application of ledger distances of H = 1.5m and H = 1.0m the basis of the scaffold becomes critical. The precise calculation by a skilled person is inevitable in these cases at least.

„Buckling Load“ applicable in case that standards are directly fixed to a rigid construction
 „Dia 1/1, 1/2, 1/3“ For reinforcing braces assembled every bay, every 2nd bay, every 3rd bay

Table 6: Capacity of Standards

System Width (m)	Centre Standards				Perimeter Standards			
	Buckling Load (kN)	Dia 1/1 (kN)	Dia 1/2 (kN)	Dia 1/3 (kN)	Buckling Load (kN)	Dia 1/1 (kN)	Dia 1/2 (kN)	Dia 1/3 (kN)
Bay Height H = 2.00m								
0.73	50.3	47.9	42.1	36.9	36.9	38.1	36.0	34.6
1.09	49.3	48.2	46.1	43.2	43.2	38.3	37.7	36.8
1.57	48.0	47.3	46.2	46.1	46.1	38.2	37.7	37.2
2.07	46.8	46.5	45.8	45.3	45.3	37.7	37.7	37.0
2.57	45.9	45.6	44.9	44.5	44.5	37.2	37.2	36.7
3.07	44.5	44.4	44.0	43.7	43.7	36.7	36.7	36.3
Bay Height H = 1.50m								
0.73	65.6	61.1	56.4	50.0	55.1	54.0	50.9	46.9
1.09	64.3	63.0	61.0	56.5	54.7	54.6	53.5	53.5
1.57	62.9	62.1	61.1	58.7	54.0	54.0	53.6	53.5
2.07	61.6	61.1	60.4	58.5	53.6	53.6	53.1	52.9
2.57	60.5	60.0	59.5	58.0	52.8	52.8	52.6	52.3
3.07	59.2	57.5	57.0	56.1	52.2	51.2	50.6	49.7
Bay Height H = 1.00m								
0.73	74.7	70.1	68.4	66.7	71.0	70.1	68.4	66.7
1.09	74.9	71.9	69.8	67.6	70.5	70.3	69.4	67.6
1.57	74.0	73.2	72.1	68.0	70.0	69.9	69.2	68.0
2.07	73.2	72.7	71.9	69.2	69.6	69.3	68.7	68.1
2.57	72.6	72.1	71.4	69.5	69.2	68.8	68.3	67.7
3.07	72.0	71.4	70.7	69.2	68.8	68.3	67.8	67.2

Capacity of Items

Decks

Table 7 contains the classification of system decks in reference to the load classes stated in EN 12811-1. Additionally the max. allowable uniformly distributed load as well as the max. concentrated (single point) load are mentioned. The max. concentrated load has to be applied to an area of min. 0.5*0.5m due to the fact that the decks are sometimes smaller it is reduced according to the width ratio. The lowest value allowed is 1.50kN. This is applicable for decks of 0.19m width. Single point load means that the area to apply this load may not be smaller than 0.5*0.5m. In case that the deck is not of sufficient width the length of the area has to be min. 0.5m the width may be reduced to the width of the deck.

Table 7: Capacity of Futuro Decks

Type of Deck	Length (m)	Load Class	Uniformly Distributed Load (kN/m ²)	Single Point Load (kN)
System deck steel 32 U-support	3.07	4	5.0	1.92
	2.57	5	7.5	1.92
	≤ 2.07	6	10.0	1.92
System deck steel 32 Tubular support	3.07	4	5.0	1.92
	2.57	5	7.5	1.92
	≤ 2.07	6	10.0	1.92
System deck steel 19 U-support	3.07	4	5.0	1.50
	2.57	5	7.5	1.50
	≤ 2.07	6	10.0	1.50
System deck steel 19 Tubular support	3.07	4	5.0	1.50
	2.57	5	7.5	1.50
	≤ 2.07	6	10.0	1.50
Alu-Access Deck with Plywood surface, U-Support	3.07	3	2.0	1.50
	2.57	3	2.0	1.50
Alu-Access Deck Alu-surface, SL-Support Alu-surface, Tubular Support	3.07	3	2.0	1.50
	2.57	4	3.0	3.00
Steel Site Stair 75 Steel Site Stair 95	2.57	3	2.0	1.50
	2.57	3	2.0	1.50
Alu-Stair U-Support Alu-Stair Tubular Support	3.07	3	2.0	1.50
	2.57	3	2.0	1.50
Alu-Deck protec U-Support (width = 610mm)	3.07	4	3.0	3.00
	2.57	5	4.5	3.00
	≤ 2.07	6	6.0	3.00

Capacity of Items

Transoms and Ledgers

The following chapter contains the capacities of transoms and ledgers. The data refers to the latest state of design at the time of writing this manual. The following transoms and or ledgers are regarded separately:

Table 8:	Single and Double Transoms U-Support
Table 9:	Single Transoms / Ledgers; Tubular Support
Table 10:	Reinforced and Double Transoms Tubular Support
Table 11:	Lattice Girders with 4 wedge heads; U-Support
Table 12:	Intermediate Transoms

For evaluating the capacity the elastic reaction between ledger and standard has been taken into account (not relevant for intermediate transoms). The self weight of decks has been considered (Steel decks 0.23 kN/m²). The separate columns of the following tables are giving the data as described:

Allow. q:	Allowable uniformly distributed load along the transom / ledger.
Deck Length:	Bay size to be supported by the transom.
Allow. p:	Allowable safe working load for the area to be supported by the transom. Should this value be bigger than the capacity of decks the decks need to be reinforced.
Load Class:	Classification according to EN 12811 considering con-centrated loads (for steel decks according to table 7, page 62) 1st column central transom, 2nd column perimeter transom *)
Allow. P:	1x P = allowable single point load in the centre of the transom 2x P = allowable single point loads equally spaced dividing the transom into three similar distances

*) At Birdcage scaffolds every transom may be considered as a perimeter transom if the deck's orientation is changed every bay.

Capacity of Items

Table 8: Capacity of Single and Double Transoms; U-Support

Transom Length (m)	allow. q (kN/m)	Deck Length (m)	allow. p* ⁾ central transom (kN/m ²)	allow. p* ⁾ perimeter transom (kN/m ²)	Load Class		allow. P (kN)
0.73 (2-board)	23.2	3.07	7.3	14.9	4	4	1 x 7.4
		2.57	8.8	17.8	5	5	
		2.07	11.0	22.2	6	6	
		1.57	14.5	29.3	6	6	
1.09 (3-board)	19.0	3.07	6.0	12.1	4	4	1 x 9.7
		2.57	7.2	14.6	5	5	
		2.07	8.9	18.1	6	6	
		1.57	11.9	24.0	6	6	
1.40 (4-board)	11.5	3.07	3.5	7.3	4	4	1 x 7.6
		2.57	4.2	8.7	4	5	
		2.07	5.3	10.9	5	6	
		1.57	7.1	14.4	5	6	
1.57	16.3	3.07	5.1	10.4	4	4	1 x 9.6 2 x 9.3
		2.57	6.1	12.5	5	5	
		2.07	7.6	15.5	5	6	
		1.57	10.2	20.5	6	6	
2.07	9.7	3.07	2.9	6.1	3	4	1 x 8.9 2 x 6.9
		2.57	3.5	7.3	4	5	
		2.07	4.5	9.1	4	6	
		1.57	5.9	12.1	5	6	
2.57	5.7	3.07	1.6	3.5	2	3	1 x 6.2 2 x 4.9
		2.57	2.0	4.2	3	4	
		2.07	2.5	5.3	3	4	
		1.57	3.4	7.0	4	5	
3.07	4.0	3.07	1.1	2.4	1	3	1 x 5.3 2 x 3.7
		2.57	1.3	2.9	1	3	
		2.07	1.7	3.6	2	4	
		1.57	2.3	4.9	3	4	

Capacity of Items

Table 9: Capacity of Single Transoms / Ledgers; Tubular Support

Transom Length (m)	allow. q (kN/m)	Deck Length (m)	allow. p*) central transom (kN/m ²)	allow. p*) perimeter transom (kN/m ²)	Load Class		allow. P (kN)
0.73	22.5	3.07	7.1	14.4	4	4	7.1
		2.57	8.5	17.3	5	5	
		2.07	10.6	21.5	6	6	
		1.57	14.1	28.4	6	6	
1.09	11.5	3.07	3.5	7.3	4	4	5.6
		2.57	4.2	8.7	4	5	
		2.07	5.3	10.9	5	6	
		1.57	7.1	14.4	5	6	
1.40	6.4	3.07	1.9	3.9	2	4	4.0
		2.57	2.3	4.8	3	4	
		2.07	2.9	6.0	3	5	
		1.57	3.8	7.9	4	5	
1.57	5.2	3.07	1.5	3.2	1	3	3.6
		2.57	1.8	3.8	2	4	
		2.07	2.3	4.8	3	4	
		1.57	3.1	6.4	3	5	
2.07	3.1	3.07	0.8	1.8	1	2	2.8
		2.57	1.0	2.2	1	3	
		2.07	1.3	2.8	1	3	
		1.57	1.7	3.7	2	4	
2.57	2.0	3.07	0.4	1.1	-	1	2.3
		2.57	0.5	1.3	-	1	
		2.07	0.7	1.7	1	2	
		1.57	1.0	2.3	1	3	
3.07	1.4	3.07	0.2	0.7	-	-	2.0
		2.57	0.3	0.9	-	1	
		2.07	0.4	1.1	-	1	
		1.57	0.7	1.6	-	2	

Capacity of Items

Table 10: Capacity of Reinforced and Double Transoms; Tubular Support

Transom Length (m)	allow. q (kN/m)	Deck Length (m)	allow. p*) central transom (kN/m ²)	allow. p*) perimeter transom (kN/m ²)	Load Class		allow. P (kN)
1.09 (reinforced)	21.8	3.07	6.9	14.0	4	4	1 x 11.2
		2.57	8.3	16.7	5	5	
		2.07	10.3	20.8	6	6	
		1.57	13.7	27.5	6	6	
1.29 (reinforced)	15.6	3.07	4.9	9.9	4	4	1 x 9.5
		2.57	5.8	11.9	5	5	
		2.07	7.3	14.8	5	6	
		1.57	9.7	19.6	6	6	
1.57	27.6	3.07	8.8	17.8	4	4	1 x 15.3 2 x 16.3
		2.57	10.5	21.2	5	5	
		2.07	13.1	26.4	6	6	
		1.57	17.3	34.9	6	6	
2.07	13.9	3.07	4.3	8.8	4	4	1 x 11.5 2 x 8.5
		2.57	5.2	10.6	5	5	
		2.07	6.5	13.2	5	6	
		1.57	8.6	17.5	6	6	
2.57	8.0	3.07	2.4	5.0	3	4	1 x 7.2 2 x 6.3
		2.57	2.9	6.0	3	5	
		2.07	3.6	7.5	4	5	
		1.57	4.9	10.0	5	6	
3.07	4.3	3.07	1.2	2.6	1	3	1 x 6.0 2 x 5.1
		2.57	1.4	3.1	1	3	
		2.07	1.8	3.9	2	4	
		1.57	2.5	5.2	3	5	

Capacity of Items

Table 11: Lattice Girders with 4 wedge heads; U-Support

Beam Length (m)	allow. q (kN/m)	Deck Length (m)	allow. p*) central transom (kN/m ²)	allow. p*) perimeter transom (kN/m ²)	Load Class		allow. P (kN)
3.07	14.5	3.07	4.5	9.2	4	4	1 x 28.6
		2.57	5.4	11.1	5	5	
		2.07	6.8	13.8	5	6	
		1.57	9.0	18.2	6	6	
4.14	10.6	3.07	3.2	6.7	4	4	1 x 25.1
		2.57	3.9	8.0	4	5	
		2.07	4.9	10.0	5	6	
		1.57	6.5	13.3	5	6	
5.14	8.4	3.07	2.5	5.2	3	4	1 x 21.1
		2.57	3.0	6.3	3	5	
		2.07	3.8	7.9	4	5	
		1.57	5.1	10.5	5	6	
6.14	6.9	3.07	2.0	4.3	3	4	2.0
		2.57	2.5	5.1	3	4	
		2.07	3.1	6.4	3	5	
		1.57	4.2	8.6	4	6	

The upper chords of the lattice girders have to reinforced to avoid buckling. This may be done by tube and fitting equipment connected to the vertical members as close to the decking level as possible.

Capacity of Items

Table 12: Capacity of Intermediate Transoms

Ledger Length (m)	allow. q (kN/m)	allow. p (kN)
0.73	18.9	6.9
1.09	8.5	4.6
1.40	5.1	3.6
1.57	4.1	3.2
2.07	2.3	2.4
2.57	1.5	2.0
3.07	1.0	1.6

Capacity of Items

The horizontal capacity of wedge head couplers may be taken from the data for $V_y = \pm 6.2 \text{ kN}$ and $M_z = \pm 14.5 \text{ kNm}$.

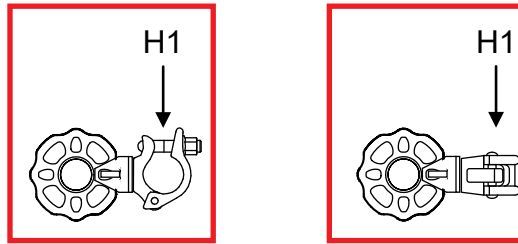

A single wedge head coupler will be able to support the following safe working load:

allow. $H_1 = 14.5 / 8.8 = 1.7 \text{ kN}$

Should at least two wedge head couplers be connected by a separate tube then the full load capacity for the horizontal load V_y can be activated.

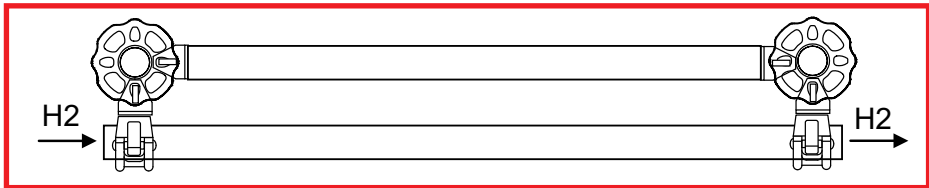

For each wedge head: allow. $H_2 = 6.2 \text{ kN}$

Capacity of Items

Wedge Head Couplers

The capacity of wedge head coupler is set by the approval Z-8.22-841. The capacity is valid for both designs 'parallel' and 'right angle'. The allowable safe working load is shown in sketches below. Elastic reinforcing data and spring capacities are to be taken from the approval directly.

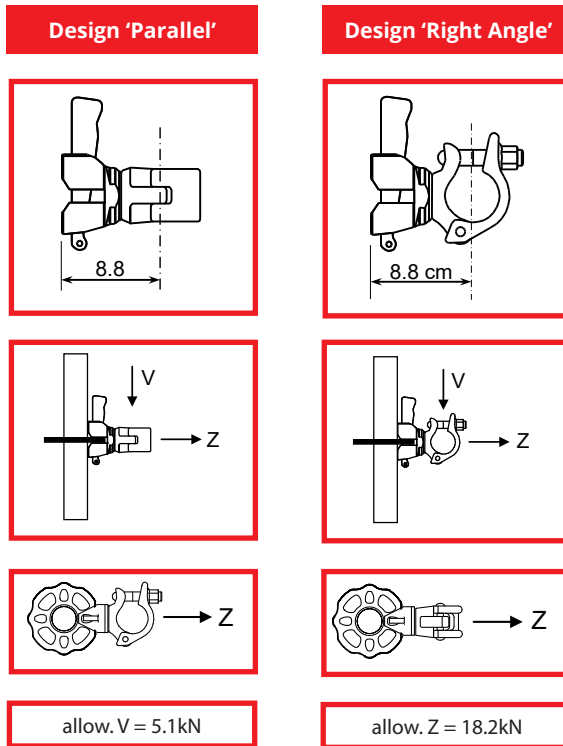

The safe working loads mentioned above are also valid for the wedge head couplers with swivel couplers. These capacities are not covered by the approval but supported by additional tests. Spring capacities for these couplers are available on demand.

Design Details

Standard

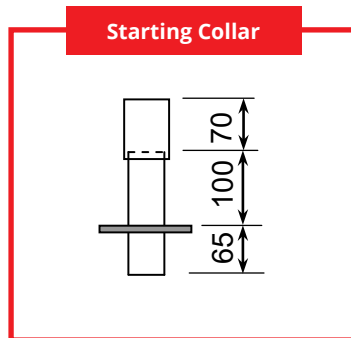
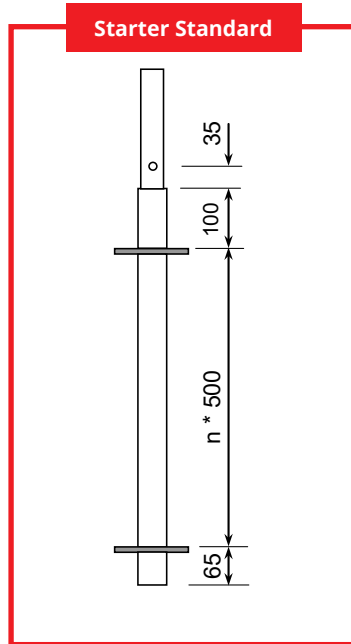
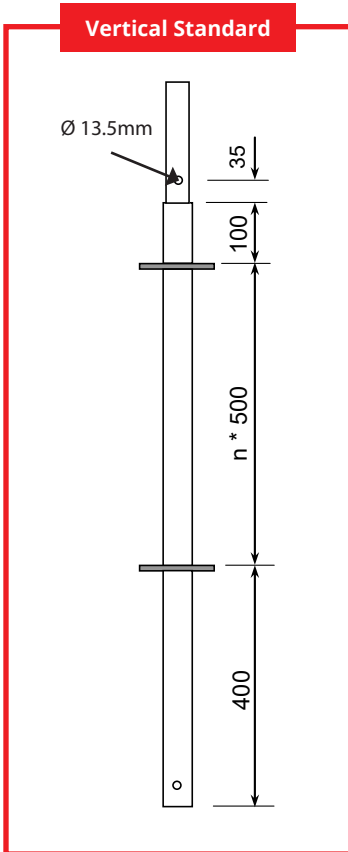

Design Details

Bolts & Pads

Specified in relation to the top of the discs.

Tubular Ledger

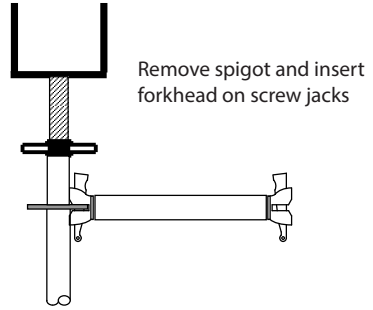
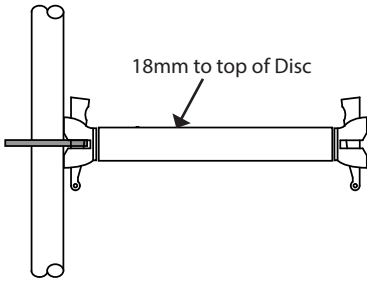

Steel Deck for Tubular Support

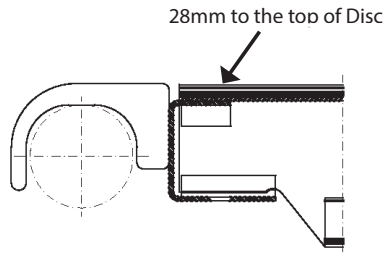

U-Transom

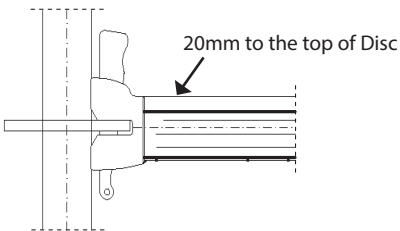

Steel Deck on U-Transom

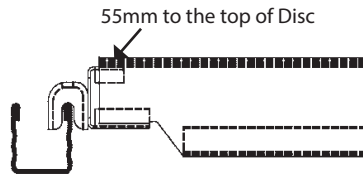

Rescue Plan

ALTRAD Futuro is a fast and simple system which when erected by suitably trained and skilled operatives improve levels of safety over traditional methods. Automatic positioning of all components including handrails without the need for levelling ensures safety whilst erecting. The system with handleable components is easily erected safely and efficiently.

However, erectors need to be mindful of the risks and plan to work as safely as possible. In accordance with the Fall from Heights Regulations 2005 (as amended), every attempt should be made to “mitigate the risk involved by prevention of falls by using work equipment or other measures to prevent fall. Where they cannot avoid working at height and where they cannot eliminate the risk of a fall, use work equipment or other measures to minimise the distance and consequences of a fall should one occur”.

Generation recommend the use of collective measures such as Advanced Guardrail systems, Hop-Ups and Steps where structural parts and handrails can be installed from a place of safety during the erection process. Alternatively the use of fall protection equipment to restrain and limit any falls. Harnesses should be worn and used at all stages of erection of ALTRAD Futuro.

The “Work at Height Regulations 2005” specifically requires every employer to take account of the need for an easy and timely evacuation in the event of an emergency where scaffolders or operatives suffer disability or falls when suspended in a harness.

A site specific Risk Assessment and Method Statement is essential in determining the plan required for the recovery of a disabled or incapacitated person. Generation recommend that contractors, employers develop their own rescue plan in accordance with the recommendations of the NASC in their documents SG4 and Guide to Formulating a Rescue Plan SG19.

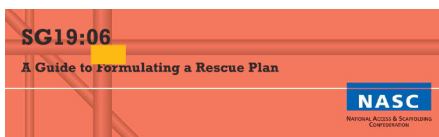

All erectors should be trained in the use of special rescue equipment and ensure all equipment for rescue is available and is fit for use at all times.

NB: Legislation is consistently being updated and users are responsible to ensure that the latest and most appropriate is used at the time.



NASC Code of Practice

ALTRAD Futuro supplied by
Generation UK Ltd has been audited
by the NASC and has met the criteria
to satisfy the NASC Code of Practice
for proprietary System Scaffold
Systems.



**SCAN ME
TO FIND**



**YOUR LOCAL
BRANCH**



**GENERATION
HIRE & SALE**

Generation UK Ltd.
Head Office, Trinity Street, Off Tat Bank Road, Oldbury, West Midlands, B69 4LA - United Kingdom
Tel. 0121 543 2950 - Fax. 0121 543 2953 - enquiries@generationuk.co.uk
www.altradgeneration.com